

Amateur Radio General Class License Class Syllabus



Based on July 1, 2015 to July 1, 2019 Question Pool

Jack Tiley AD7FO, Spokane Valley, WA

Revision: 1.03 – 9 August 2015

© Jack Tiley - January 2015

Proof read by Rick Nungester WA6NDR

Please email the Author at ad7fo@arrl.net before using this syllabus to insure you have the latest revision.

General License Class Syllabus

Written by Jack Tiley AD7FO

All questions are shown exactly as they will appear in the test with only the correct answer shown (**in green bold text**), which in the author's view makes it easier when you see the other choices in your exam to identify the correct answer. Question numbers have been included so you can go to the ARRL General Class License Manual, or the question pool itself at (<http://ncvec.org/page.php?id=364>), to see the additional choices in the exam for each question.

This material is based on the published 2015 General Class License question pool, effective July 1, 2015, with additional information added by the author (*in italicized blue text*).

You do not need a copy of the current ARRL General Class License Manual. All of the questions that may be in the exam are contained in this syllabus. It is suggested you obtain a recent copy of the ARRL Handbook which will serve as a useful as a reference to help understand the technical areas covered in this syllabus and for Ham Radio in general. You do not need the latest edition of the ARRL Handbook, any edition within the past 5-8 years is sufficient as the technical content does not change.

Many of the illustrations used in this syllabus were copied from the ARRL Handbook CD-ROM, scanned from the license manual with permission from the copyright owner, ARRL, as well as other public sites on the web. This document has been written to assist students and instructors and may be distributed freely as long as no charge for the material is made (except for reproduction costs associated with delivering paper copies or electronic copies on CD-ROM's) and this note of copyright permission is not removed.

The electronic file of this syllabus may be too large to be e-mailed so an alternate form of distribution such as color printed copies, CD-ROM or web posting will be required (it is recommended if this is posted to a web site that you link that site to the Inland Empire VHF club web site www.vhfclub.org which will always have the latest revision).

While every effort was made to insure the accuracy of the material herein, this material was prepared by an ordinary human being and it is likely that a few typographical, spelling or other errors remain. The author can be contacted at ad7fo@arrl.net. Corrections are always welcome and appreciated.

Additional information and resources to help you study for the General Class License can be found on the ARRL web site (www.arrl.org). This site has articles and resources for reference materials on all aspects of the exam questions and Amateur Radio in general.

Authors class Requirements when he is teaching a General license class.

1. It is required that students each have a color printed copy of this syllabus to study from and that they bring to class. The instructor will be teaching from the syllabus during the class. All the possible questions that could be in the exam are covered in this syllabus.

This syllabus in addition to the Extra and Technician syllabus's may be down loaded from the Inland Empire VHF Club web site www.vhfclub.org under the Training link on the home page.

2. A printed and bound copy of this syllabus can be purchased from The UPS Store located at 2910 East 57th Avenue #5, Spokane, WA 99223 Phone (509) 448-6368 (ask for Mike-KD7GHZ or Richard- KE7DQC) for around \$12. These can be picked up at the store or can be ordered and shipped to a student.

3. Students will need a basic scientific calculator that they are familiar with operating that is capable of normal math functions, square roots, trigonometry and Base 10 Log functions (all basic scientific calculators have these functions). Scientific calculators are available from office supply stores for around \$10 to \$15 if you do not already have one. The Texas Instrument 30 Series calculators meet these requirements. It is recommended you do not purchase a programmable calculator as it may not be allowed in the test session. Cell phone calculators are not allowed in test sessions.

4. Students need a desire to learn and to ask questions if they do not understand something that is being taught.

5. To obtain a General license upgrade students must have passed the Technician license (Element 2) exam and take and pass the General Class written exam (element 3)

- There are 35 questions on the General exam,
 - All questions are multiple choices (4 choices). You must obtain a passing score of 74% (26 correct answers).
 - Questions come from a published pool of questions (all possible questions are covered in this syllabus).
 - The number of possible questions for each topic area is fixed and shown for each question group in the syllabus.

6. There are a number of on-line practice sites with practice exams you can take with real exam questions for practice. Listed below are three sites where you can find practice exams:

<http://aa9pw.com/radio/>

<http://www.eham.net/exams>

<http://www.qrz.com/hamtest>

<http://www.hamstudy.org>

<http://www.arrl.org/exam-practice>

<http://www.hamradionation.com>

<http://www.hamexam.org>

<http://www.hamradiolicenseexam.com>

License search websites (find your license or someone else's license)

<http://www.wireless.fcc.gov/uls>

<http://www.arrl.org/fcc/search>

<http://www.qrz.com>

About The Author



Education:

Electrical Engineering, Penn State University

Work Experience:

Hewlett Packard: Thirty four years filling various positions (retired in 2004)

- RF Products Division in Spokane WA – 1981 to 2004 - Regional Sales Support, Application Engineering, World Wide Sales Management, Systems Development and Product Management
- Valley Forge PA - from 1969 until 1981 - Engineering Technical Support, Technical Customer Training and Field Sales Engineer

American Electronics Laboratories: Nine years working in and managing a Metrology (Calibration Standards) Laboratory responsible for maintaining test instruments and their calibration traceability to the National Bureau of Standards (*NBS*) now the National Institute of Standards and Technology (*NIST*) in Colmar Pennsylvania.

Jerrold Electronics: 2 years as a Technician at Jerrold Electronics R&D Laboratory in Hatboro PA.

Hobbies:

- Amateur Radio, Test Equipment, Electronics in general.
- Teaching amateur radio classes

Amateur Radio Activities:

- Teaching and mentoring. Teaching Technician (1 day class), General (2 day class) and Extra (3 day class) License Classes using training materials I have developed.
- Teaching ARRL EMCOMM class with a power point presentation I have written (2-1/2 day class)
- Wrote and presented twenty plus one hour technical talks for local ham radio clubs (Available from the Author).
- I provide a radio and general purpose test table every year at the Spokane Hamfest for folks to test their radios and other electronic hamfest treasures.
- Attending as many hamfests as I can

ARRL Appointments:

- ARRL VE (Volunteer Examiner)
- ARRL Technical Specialist for Spokane area
- ARRL Technical Coordinator for EWA
- ARRL Registered Instructor
- ARRL Certified EMCOMM instructor

Other:

- Officer in the Inland Empire VHF Club
- Member of the Spokane County ARES/RACES (past AEC)

2015-2019 General Class – FCC Element- 3 Effective July 1, 2015 thru July 1 2019

SUBELEMENT G1 COMMISSION'S RULES [5 Exam Questions-5 Groups]

G1A - General Class control operator frequency privileges; primary and secondary allocations
G1B - Antenna structure limitations; good engineering and good amateur practice; beacon operation; prohibited transmissions; retransmitting radio signals
G1C - Transmitter power regulations; data emission standards
G1D - Volunteer Examiners and Volunteer Examiner Coordinators; temporary identification
G1E – Control categories; repeater regulations; harmful interference; third party rules; ITU regions; automatically controlled digital station

SUBELEMENT G2 OPERATING PROCEDURES [5 Exam Questions-5 Groups]

G2A - Phone operating procedures; USB/LSB conventions; procedural signals; breaking into a contact; VOX operation
G2B - Operating courtesy; band plans; emergencies, including drills and emergency communications
G2C - CW operating procedures and procedural signals; Q signals and common abbreviations; full break in
G2D - Amateur Auxiliary; minimizing interference; HF operations
G2E - Digital operating; procedures, procedural signals and common abbreviations

SUBELEMENT G3 RADIO WAVE PROPAGATION [3 Exam Questions-3 Groups]

G3A - Sunspots and solar radiation; ionospheric disturbances; propagation forecasting and indices
G3B - Maximum Usable Frequency; Lowest Usable Frequency; propagation
G3C - Ionospheric layers; critical angle and frequency; HF scatter; Near-Vertical Incidence Skywave

SUBELEMENT G4 AMATEUR RADIO PRACTICES [5 Exam Questions-5 groups]

G4A – Station Operation and set up
G4B - Test and monitoring equipment; two-tone test
G4C - Interference with consumer electronics; grounding; DSP
G4D - Speech processors; S meters; sideband operation near band edges
G4E - HF mobile radio installations; emergency and battery powered operation

SUBELEMENT G5 ELECTRICAL PRINCIPLES

[3 Exam Questions–3 Groups]

G5A - Reactance; inductance; capacitance; impedance; impedance matching

G5B - The Decibel; current and voltage dividers; electrical power calculations; sine wave root-mean-square (RMS) values; PEP calculations

G5C – Resistors, capacitors, and inductors in series and parallel; transformers

SUBELEMENT G6 CIRCUIT COMPONENTS

[2 Exam Questions–2 Groups]

G6A – Resistors; Capacitors; Inductors; Rectifiers; solid state diodes and transistors; vacuum tubes; batteries

G6B - Analog and digital integrated circuits (ICs); microprocessors; memory; I/O devices; microwave ICs (MMICs); display devices

SUBELEMENT G7 PRACTICAL CIRCUITS

[3 Exam Questions–3 Groups]

G7A Power supplies; and schematic symbols

G7C - Receivers and transmitters; filters, oscillators

SUBELEMENT G8 SIGNALS AND EMISSIONS

[3 Exam Questions–3 Groups]

G8A - Carriers and modulation; AM; FM; single sideband; modulation envelope; digital modulation; over modulation

G8B - Frequency mixing; multiplication; bandwidths of various modes; deviation

G8C – Digital emission modes

SUBELEMENT G9 ANTENNAS AND FEEDLINES

[4 Exam Questions–4 Groups]

G9A - Antenna feed lines; characteristic impedance, and attenuation; SWR calculation, measurement and effects; matching networks

G9B - Basic antennas

G9C - Directional antennas

G9D - Specialized antennas

SUBELEMENT G0 ELECTRICAL AND RF SAFETY

[2 Exam Questions–2 Groups]

G0A - RF safety principles, rules and guidelines; routine station evaluation

G0B - Safety in the ham shack; electrical shock and treatment, safety grounding, fusing, interlocks, wiring, antenna and tower safety

US Amateur Radio Bands

US AMATEUR POWER LIMITS

FCC 97.313 An amateur station must use the minimum transmitter power necessary to carry out the desired communications. (b) No station may transmit with a transmitter power exceeding 1.5 kW PEP.

Effective Date
March 5, 2012

Published by:
ARRL AMATEUR RADIO
www.arrl.org
225 Main Street, Newington, CT USA 06111-1494

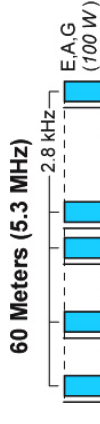
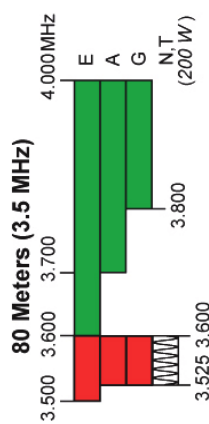

5330.5 5346.5 5357.0 5371.5 5403.5 kHz
General, Advanced, and Amateur Extra licensees may operate on these five channels on a secondary basis with a maximum effective radiated output of 100 W PEP. Permitted operating modes include upper sideband voice (USB), CW, RTTY, PSK31 and other digital modes such as PACTOR III as defined by the FCC Report and Order of November 18, 2011. USB is limited to 2.8 kHz centered on 5332, 5348, 5358.5, 5373 and 5405 kHz. CW and digital emissions must be centered 1.5 kHz above the channel frequencies indicated above. Only one signal at a time is permitted on any channel.

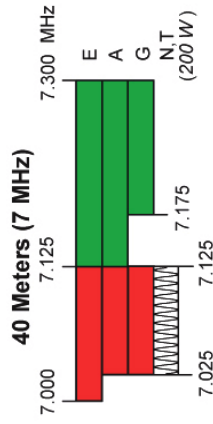

Phone and image modes are permitted between 7.075 and 7.100 MHz for FCC licensed stations in ITU Regions 1 and 3 and by FCC licensed stations in ITU Region 2 West of 130 degrees West longitude or South of 20 degrees North latitude. See Sections 97.305(c) and 97.307(f)(11).
Novice and Technician licensees outside ITU Region 2 may use CW only between 7.025 and 7.075 MHz and between 7.100 and 7.125 MHz. 7.200 to 7.300 MHz is not available outside ITU Region 2. See Section 97.301(e). These emissions do not apply to stations in the continental US.

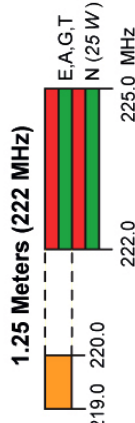
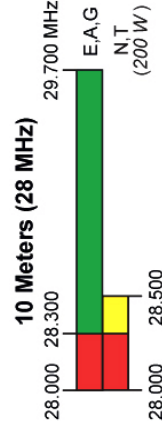
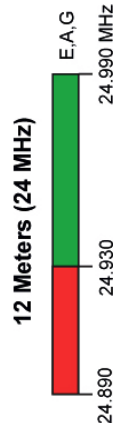
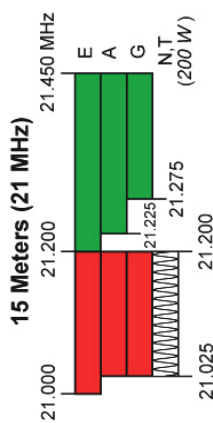
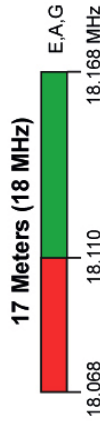
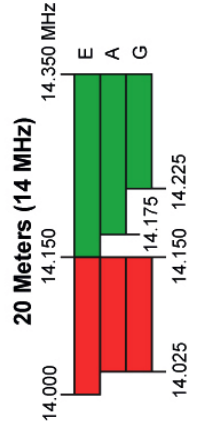

*Geographical and power restrictions may apply to all bands above 420 MHz. See The ARRL Operating Manual for information about your area.

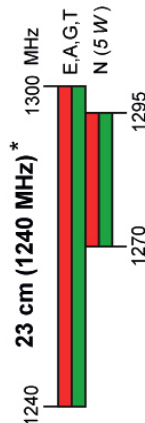

All licensees except Novices are authorized all modes on the following frequencies:

2300-2310 MHz	10.0-10.5 GHz *	122.25-123.0 GHz
2390-2450 MHz	24.0-24.25 GHz	134-141 GHz
3300-3500 MHz	47.0-47.2 GHz	241-250 GHz
5650-5925 MHz	76.0-81.0 GHz	All above 275 GHz

* No pulse emissions

KEY

Note: CW operation is permitted throughout all amateur bands.

MCW is authorized above 50.1 MHz, except for 144.0-144.1 and 219-220 MHz. Test transmissions are authorized above 51 MHz, except for 219-220 MHz.

- █ = RTTY and data
- █ = phone and image
- █ = CW only
- █ = SSB phone
- █ = USB phone, CW, RTTY, and data
- █ = Fixed digital message forwarding systems only

- E = Amateur Extra
- A = Advanced
- G = General
- T = Technician
- N = Novice

See ARRLWeb at www.arrl.org for detailed band plans.

ARRL
We're At Your Service

ARRL Headquarters:
860-594-0200 (Fax 860-594-0259)
email: hq@arrl.org

Publication Orders:
www.arrl.org/shop
Toll-Free 1-888-277-5289 (860-594-0355)
email: orders@arrl.org

Membership/Circulation Desk:
www.arrl.org/membership
Toll-Free 1-888-277-5289 (860-594-0338)
email: membership@arrl.org

Getting Started in Amateur Radio:
Toll-Free 1-800-526-3942 (860-594-0355)
email: newham@arrl.org

Exams: 860-594-0300 email: vec@arrl.org

SUBELEMENT G1 - COMMISSION'S RULES

[5 Exam Questions - 5 Groups]

Note: The number in brackets after the question number is the FCC Part 97 rule that applies.

G1A - General Class control operator frequency privileges; primary and secondary allocations

note: See the US Amateur Radio Bands chart on Page 7 for questions G1A01 thru G1A11.

G1A01 [97.301(d)]

On which of the following bands is a General Class license holder granted all amateur frequency privileges?

160, 60, 30, 17, 12, and 10 meters

Amateur Radio frequency bands are frequently referred to by their wavelength. Wavelength (meters) is equal to the speed of light (meters per second) divided by the frequency (Hz). Since the speed of light is approximately 3,000,000 meters per second the wavelength is equal to $300,000,000 \div \text{Frequency (Hz)}$.

or $\sim 300 \div \text{frequency (MHz)}$

G1A02 [97.305]

On which of the following bands is phone operation prohibited?

30 meters

Only RTTY and data are allowed on 30 meters

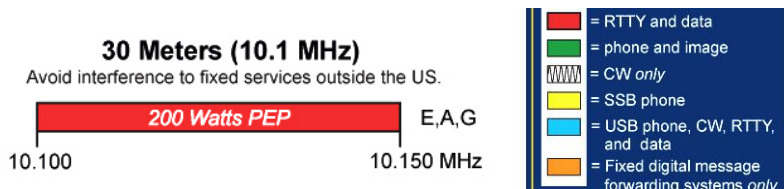

G1A03 [97.305]

On which of the following bands is image transmission prohibited?

30 meters

See answer above in G1A02

G1A04 [97.303 (h)]

Which of the following amateur bands is restricted to communication on only specific channels, rather than frequency ranges?

60 meters

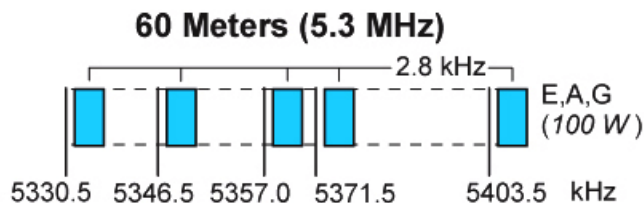

G1A05 [97.301(d)]

Which of the following frequencies is in the General Class portion of the 40-meter band?

7.250 MHz

The test question has only two reasonable answers for the 40 meter band specified in the question both 7.25 MHz and 7.50 MHz would be reasonable choices. If you calculate the band frequency using the formula $\text{frequency(MHz)} = 300/\text{band}$ then dividing the band (40 meters) into 300 ($\text{frequency} = 300 \div 40$) by the band you would come up with an answer somewhere close to 7.5 MHz, but the question asks which frequency is in the general class portion of the band. If you look at the US Amateur Radio Bands on page 7 you will see that the 40 meter amateur band stops at 7.3 MHz. so therefore the 7.25 MHz answer would be correct.

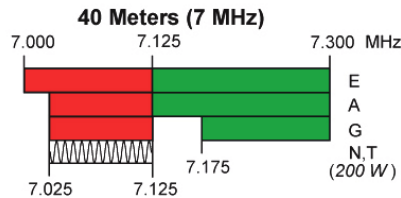

G1A06 [97.301(d)]

Which of the following frequencies is within the General Class portion of the 75-meter phone band?

3,900 kHz

The General class portion of the 80 meter band is from 3.525 MHz to 3.600 MHz but restricted RTTY and data, no voice (phone) allowed. The 3.8 to 4.00 MHz is available for voice (phone). The 80 meter band is sometimes referred to as the 75 and 80 meter band.

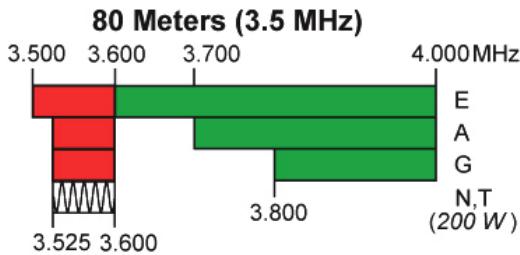

G1A07 [97.301(d)]

Which of the following frequencies is within the General Class portion of the 20-meter phone band?

14,305 kHz

The General class portion of the 20 meter phone band is from 14,225 kHz to 14,350 kHz.

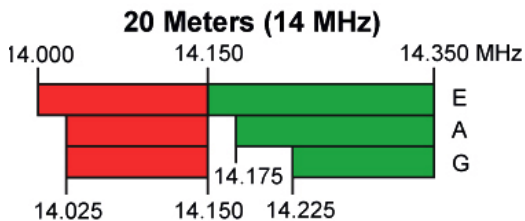

G1A08 [97.301(d)]

Which of the following frequencies is within the General Class portion of the 80-meter band?

C. 3560 kHz

The General class portion of the 80 meter band is from 3,525 kHz to 3,600 kHz and 3,700 kHz to 4,000 kHz

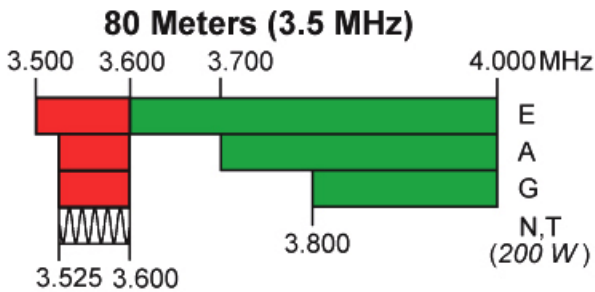

G1A09 [97.301(d)]

Which of the following frequencies is within the General Class portion of the 15-meter band?

21,300 kHz

The General class portion of the 15 meter band is from 21,025 kHz to 21,200 kHz and 21,275 kHz to 21,450 kHz

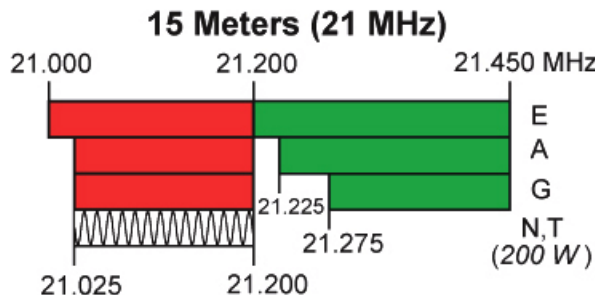

G1A10 [97.301(d)]

Which of the following frequencies is available to a control operator holding a General Class license?

A. 28.020 MHz

B. 28.350 MHz

C. 28.550 MHz

D. All of these choices are correct

The General class portion of the 10 meter band is from 28.000 MHz to 29.700 MHz

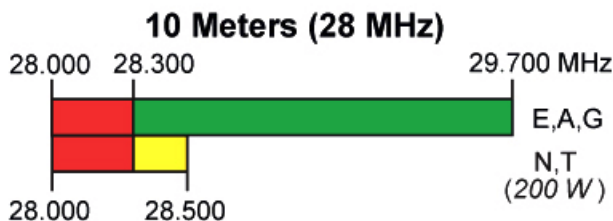

G1A11 [97.301]

When General Class licensees are not permitted to use the entire voice portion of a particular band, which portion of the voice segment is generally available to them?

The upper frequency end

G1A12 [97.303]

Which of the following applies when the FCC rules designate the Amateur Service as a secondary user on a band?

Amateur stations are allowed to use the band only if they do not cause harmful interference to primary users

The 30 meter and 60 meter bands are examples of where we are secondary users.

G1A13 [97.303(h)(2)(j)]

What is the appropriate action if, when operating on either the 30- or 60- meter bands, a station in the primary service interferes with your contact?

Move to a clear frequency or stop transmitting

G1A14 [97.301(d)]

In what ITU region is operation in the 7.175 to 7.300 MHz band permitted for a control operator holding an FCC issued General Class license?

Region 2



G1B - Antenna structure limitations; good engineering and good amateur practice; beacon operation; prohibited transmissions; retransmitting radio signals

G1B01 [97.15(a)]

What is the maximum height above ground to which an antenna structure may be erected without requiring notification to the FAA and registration with the FCC, provided it is not at or near a public use airport?

200 feet

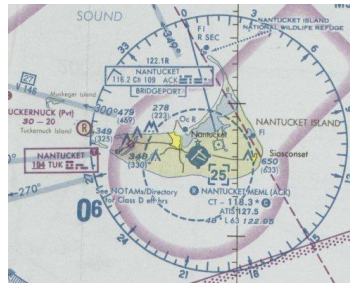

G1B02 [97.203(b)]

With which of the following conditions must beacon stations comply?

There must be no more than one beacon signal transmitting in the same band from the same station location

The northern California DX Foundation (NCDXF) in cooperation with the International Amateur Radio Union (IARU) has constructed and operates a worldwide network of High Frequency (HF) radio beacons operating at 100 watts on 14.100, 18.110, 21.150 and 28.200 MHz. These beacons help both Amateur Radio and commercial HF radio users to access the current condition of the atmosphere and to determine where the band is open. The entire system has been built and is operated by volunteers at no cost.

In principle, one can simply listen on the beacon frequencies and copy the CW call signs of the various beacons (sent at 22 WPM). Because transmit times are precisely known it is easy to know which beacon you are hearing whether you can copy the code or if the signal is weak.

G1B03 [97.3(a)(9)]

Which of the following is a purpose of a beacon station as identified in the FCC rules?

Observation of propagation and reception

G1B04 [97.113(b)]

Which of the following must be true before amateur stations may provide communications to broadcasters for dissemination to the public?

The communications must directly relate to the immediate safety of human life or protection of property and there must be no other means of communication reasonably available before or at the time of the event

G1B05 [97.113(c)]

When may music be transmitted by an amateur station?

When it is an incidental part of a manned space craft retransmission.

Not at any other time. Be sure any stereos, radios or TV's cannot be heard in the background when you transmit.

G1B06 [97.113(a)(4) and 97.207(f)]

When is an amateur station permitted to transmit secret codes?

To control a space station

Secret codes are not allowed at any time or for any other purpose other than space station control.

G1B07 [97.113(a)(4)]

What are the restrictions on the use of abbreviations or procedural signals in the Amateur Service?

They may be used if they do not obscure the meaning of a message

Procedurals are three letter abbreviations originally used to shorten transmissions on CW. Examples are included in the Reference materials section at the end on pages 106 to 109.

G1B08 [97.101(a)]

When choosing a transmitting frequency, what should you do to comply with good amateur practice?

- A. Insure that the frequency and mode selected are within your license class privileges**
- B. Follow generally accepted band plans agreed to by the Amateur Radio community.**
- C. Monitor the frequency before transmitting**
- D. All of these choices are correct**

G1B09 [97.113(a)(3)]

When may an amateur station transmit communications in which the licensee or control operator has a pecuniary (monetary) interest?

When other amateurs are being notified of the sale of apparatus normally used in an amateur station and such activity is not done on a regular basis

G1B10 [97.203(c)]

What is the power limit for beacon stations?

100 watts PEP output

PEP is the Peak Envelope Power of your transmission (see page 95 in the appendix).

G1B11 [97.101(a)]

How does the FCC require an amateur station to be operated in all respects not specifically covered by the Part 97 rules?

In conformance with good engineering and good amateur practice

G1B12 [97.101(a)]

Who or what determines "good engineering and good amateur practice" as applied to the operation of an amateur station in all respects not covered by the Part 97 rules?

The FCC (Federal Communications Commission)

G1C - Transmitter power regulations; data emission standards

G1C01 [97.313(c)(1)]

What is the maximum transmitting power an amateur station may use on 10.140 MHz?

200 watts PEP output

200 watt PEP is the maximum allowed on the 30 meter band and 10.140 is in the 30 meter band.

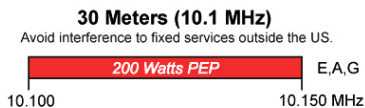

G1C02 [97.313(a),(b)]

What is the maximum transmitting power an amateur station may use on the 12-meter band?

1500 watts PEP output

G1C03 [97.303(h)(1)]

What is the maximum bandwidth permitted by FCC rules for Amateur Radio stations transmitting on USB frequencies in the 60-meter band?

2.8 kHz

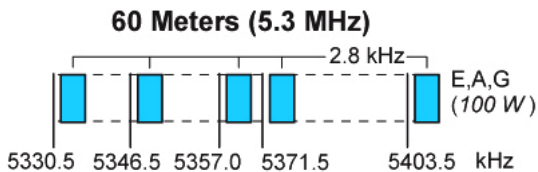

note: See US Amateur Radio Band Plan on page 7.

G1C04 [97.313(a)]

Which of the following limitations apply to transmitter power on **every amateur band**?

Only the minimum power necessary to carry out the desired communications should be used

G1C05 [97.313(c)(2)]

Which of the following is a limitation on transmitter power on the 28 MHz band for a General Class control operator?

1500 watts PEP output

G1C06 [97.313]

Which of the following is a limitation on transmitter power on the 1.8 MHz band?

1500 watts PEP output

G1C07 [97.305(c), 97.307(f)(3)]

What is the maximum symbol rate permitted for RTTY or data emission transmission on the 20-meter band?

300 baud

The speed of the data is expressed in bits per second or Baud Rate. Baud rate refers to the number of signal or symbol changes that occur per second. A symbol may contain one or more bits.

G1C08 [97.307(f)(3)]

What is the maximum symbol rate permitted for RTTY or data emission transmitted at frequencies below 28 MHz?

300 baud

For frequencies below 28 MHz, the maximum baud rate for RTTY is 300.

For frequencies in the 10 meter band the maximum baud rate for RTTY is 1200.

For frequencies in the 2 meter band the maximum baud rate for RTTY is 19.6K.

For frequencies in the 1.25 meter band the maximum baud rate for RTTY is 56K.

G1C09 [97.305(c) and 97.307(f)(5)]

What is the maximum symbol rate permitted for RTTY or data emission transmitted on the 1.25-meter and 70-centimeter bands?

56 kilobaud

G1C10 [97.305(c) and 97.307(f)(4)]

What is the maximum symbol rate permitted for RTTY or data emission transmissions on the 10-meter band?

1200 baud

G1C11 (B) [97.305(c) and 97.307(f)(5)]

What is the maximum symbol rate permitted for RTTY or data emission transmissions on the 2-meter band?

19.6 kilobaud

G1D - Volunteer Examiners and Volunteer Examiner Coordinators; temporary identification

G1D01 [97.501, 97.505(a)]

Who may receive credit for the elements represented by an expired amateur radio license?

Any person who can demonstrate that they once held a FCC issued General, Advanced, or Amateur Extra class license that was not revoked by the FCC.

This means that if you have an expired General, Advanced or Extra license that expired more than two years ago you can have your license re-instated to its previous level by producing a copy of your old license or a copy of your name and call sign in an old call book and re-taking and passing the level 2 (Technician) license exam, assuming your license was not revoked by the FCC.

G1D02 [97.509(b)(3)(i)]

What license examinations may you administer when you are an accredited VE holding a General Class operator license?

Technician only

G1D03 [97.9(b)]

On which of the following band segments may you operate if you are a Technician Class operator and have a CSCE (*Certificate of Successful Completion of Exam*) for General Class privileges?

On any General or Technician Class band segment

G1D04 [97.509(3)(i)(c)]

Which of the following is a requirement for administering a Technician Class license examination?

At least three General Class or higher VEs must observe the examination

G1D05 [97.509(b)(3)(i)]

Which of the following must a person have before they can be administering a VE for a Technician Class license examination?

An FCC General Class or higher license and VEC accreditation

G1D06 [97.119(f)(2)]

When must you add the special identifier "AG" after your call sign if you are a Technician Class licensee and have a CSCE (*Certificate of Successful Completion of Exam*) for General Class operator privileges, but the FCC has not yet posted your upgrade on its website?

Whenever you operate using General Class frequency privileges

G1D07 [97.509(b)(1)]

Volunteer Examiners are accredited by what organization?

A Volunteer Examiner Coordinator

There are two common ones are the ARRL VEC and the W5YI VEC But there are as 12 others. See <http://www.ncvec.org/page.php?id=318> for a list of others.

G1D08 [97.509(b)(3)]

Which of the following criteria must be met for a non-U.S. citizen to be an accredited Volunteer Examiner?

The person must hold an FCC granted Amateur Radio license of General Class or above

G1D09 [97.9(b)]

How long is a Certificate of Successful Completion of Examination (CSCE) valid for exam element credit?

365 days

G1D10 [97.509(b)(2)]

What is the minimum age that one must be to qualify as an accredited Volunteer Examiner?

18 years

G1D11 (D)

If a person has an expired FCC issued amateur radio license of General Class or higher, what is required before they can receive a new license?

The applicant must pass the current element 2 (Technician) exam

They must also show proof of the previous license level that they held (a Copy of expired license or an old call book with their name and license listed).

G1E – Control categories; repeater regulations; harmful interference; third party rules; ITU regions; automatically controlled digital station

G1E01 [97.115(b)(2)]

Which of the following would disqualify a third party from participating in stating a message over an amateur station?

The third party's amateur license has been revoked and not reinstated

Ham radio is frequently used to send messages on behalf of unlicensed persons or organizations. One of the oldest activities is the sending of messages, relaying them from station to station until delivered by a

Amateur Radio operator near the addressee. This is third party communication. The word Relay in the Amateur Radio Relay League (ARRL) refers to this amateur radio activity.

G1E02 [97.205(b)]

When may a 10-meter repeater retransmit the 2-meter signal from a station having a Technician Class control operator?

Only if the 10-meter repeater control operator holds at least a General Class license

An amateur radio repeater is a remote station that receives an amateur radio signal and retransmits it on a different frequency and usually at a higher power level, so that the signal can cover longer distances beyond line of sight. Repeaters are usually located on hilltops or on tall buildings. Amateur radio repeaters are similar in concept to those used by public safety entities (police, fire department, businesses, government, military, and more). Amateur radio repeaters may use commercially packaged repeater systems that have been adjusted to operate within amateur radio frequency bands, but more often amateur repeaters are assembled from receivers, transmitters, controllers, power supplies, antennas, duplexers and other components, from various sources.

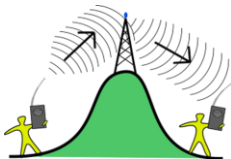

G1E03 [97.221]

What is required to conduct communications with a digital station operating under automatic control outside the automatic control band segments?

The station initiating the contact must be under local or remote control

Automatic control refers stations interfacing with the internet

G1E04 [97.13(b), 97.303, 97.311(b)]

Which of the following conditions require a licensed Amateur Radio operator to take specific steps to avoid harmful interference to other users or facilities?

A. When operating within one mile of an FCC Monitoring Station

B. When using a band where the Amateur Service is secondary

C. When a station is transmitting spread spectrum emissions

D. All of these choices are correct

Protected FCC Monitoring Stations are located at the following geographical coordinates :

Allegan, Michigan, 42°36'20.1" N. Latitude, 85°57'20.1" W. Longitude

Belfast, Maine, 44°26'42.3" N. Latitude, 69°04'56.1" W. Longitude

Canandaigua, New York, 42°54'48.2" N. Latitude, 77°15'57.9" W. Longitude

Douglas, Arizona, 31°30'02.3" N. Latitude, 109°39'14.3" W. Longitude

Ferndale, Washington, 48°57'20.4" N. Latitude, 122°33'17.6" W. Longitude

Grand Island, Nebraska, 40°55'21.0" N. Latitude, 98°25'43.2" W. Longitude

Kenai, Alaska, 60°43'26.0" N. Latitude, 151°20'15.0" W. Longitude

Kingsville, Texas, 27°26'30.1" N. Latitude, 97°53'01.0" W. Longitude

Laurel, Maryland, 39°09'54.4" N. Latitude, 76°49'15.9" W. Longitude

Livermore, California, 37°43'29.7" N. Latitude, 121°45'15.8" W. Longitude

Powder Springs, Georgia, 33°51'44.4" N. Latitude, 84°43'25.8" W. Longitude

Santa Isabel, Puerto Rico, 18°00'18.9" N. Latitude, 66°22'30.6" W. Longitude

G1E05 [97.115(a)(2),97.117]

What types of messages for a third party in another country may be transmitted by an amateur station?

Only messages relating to Amateur Radio or remarks of a personal character, or messages relating to emergencies or disaster relief

G1E06 [97.205(c)]

Which of the following applies in the event of interference between a coordinated repeater and an uncoordinated repeater?

The licensee of the uncoordinated repeater has primary responsibility to resolve the interference

G1E07 [97.115(a)(2)]

With which foreign countries is third party traffic **prohibited**, except for messages directly involving emergencies or disaster relief communications?

Every foreign country, unless there is a third party agreement in effect with that country
A list of countries with third party agreements is listed in the appendix on pages 104 and 105.

G1E08 [97.115(a)(b)]

Which of the following is a requirement for a non-licensed person to communicate with a foreign Amateur Radio station from a station with an FCC-granted license at which an FCC licensed control operator is present?

The foreign amateur station must be in a country with which the United States has a third party agreement

G1E09 [97.119(b)(2)]

What language must be used when identifying your station if you are using a language other than English in making a contact using phone emission?

English only

G1E10 [97.205(b)]

What portion of the 10-meter band is available for repeater use?

The portion above 29.6 MHz

G1E11 [97.221]

Which of the following is the FCC term for an unattended digital station that transfers messages to and from the Internet?

Automatically controlled digital station

G1E12 [97.115]

Under what circumstances are messages that are sent via digital modes exempt from Part 97 third party rules that apply to other modes of communication?

Under no circumstances

G1E13 [97.221, 97.305]

On what bands may automatically controlled stations transmitting RTTY or data emissions communicate with other automatically controlled digital stations?

Anywhere in the 1.25 meter or shorter wavelength bands, and in specified segments of the 80-meter through 2-meter bands

See the US Amateur Radio Band plan on page 7.

SUBELEMENT G2 - OPERATING PROCEDURES

[5 Exam Questions - 5 Groups]

G2A - Phone operating procedures; USB/LSB conventions; procedural signals; breaking into a contact; VOX operation

G2A01

Which sideband is most commonly used for voice communications on frequencies of 14 MHz or higher?

Upper sideband



As a general Rule all phone (voice) communication above 10 MHz is upper sideband and phone (voice) communication below 10 MHz is lower sideband.

G2A02

Which of the following modes is most commonly used for voice communications on the 160-meter, 75-meter, and 40-meter bands?

Lower sideband

As a general Rule all Phone (voice) communication below 10 MHz is lower sideband and all Phone (voice) communication above 10 MHz is upper sideband.

G2A03

Which of the following is most commonly used for SSB voice communications in the VHF and UHF bands?

Upper sideband

All the VHF and UHF bands are higher than 10 MHz so the general rule of upper side band above 10 MHz applies.

G2A04

Which mode is most commonly used for voice communications on the 17-meter and 12-meter bands?

Upper sideband

Since the 17 meter band is above 10 MHz the general rule of upper sideband applies.

G2A05

Which mode of voice communication is most commonly used on the HF amateur bands?

Single sideband

G2A06

Which of the following is an advantage when using single sideband as compared to other analog voice modes on the HF amateur bands?

Less bandwidth used and greater power efficiency

You are only transmitting one of the sidebands and no carrier, therefore your signal occupies less bandwidth and you are not transmitting a carrier or the other sideband. See the illustration in G2A01.

G2A07

Which of the following statements is true of the single sideband voice mode?

Only one sideband is transmitted; the other sideband and carrier are suppressed

See the illustration in G2A01.

G2A08

Which of the following is a recommended way to break into a contact when using phone?

Say your call sign during a break between transmissions by the other stations

G2A09

Why do most amateur stations use lower sideband on the 160-meter, 75-meter and 40-meter bands?

Current amateur practice is to use lower sideband on these frequency bands

As a general Rule all phone (voice) communication below 10 MHz is lower sideband and all phone (voice) communication above 10 MHz is upper sideband.

G2A10

Which of the following statements is true of voice VOX operation versus PTT operation?

It allows "hands free" operation

VOX is voice activated transmit. When a voice signal is detected at the microphone the transceiver automatically goes to the transmit mode and after the voice signal goes away the transceiver reverts to the receive mode. PTT or the Push To Talk mode is where you must manually activate the transmit mode, usually with a button on the microphone.

G2A11

What does the expression "CQ DX" usually indicate?

The caller is looking for any station outside their own country

G2B - Operating courtesy; band plans; emergencies, including drills and emergency communications

G2B01

Which of the following is true concerning access to frequencies in non-emergency situations?

Except during FCC declared emergencies, no one has priority access to frequencies

G2B02

What is the first thing you should do if you are communicating with another amateur station and hear a station in distress break in?

Acknowledge the station in distress and determine what assistance may be needed

G2B03

If propagation changes during your contact and you notice increasing interference from other activity on the same frequency, what should you do?

As a common courtesy, move your contact to another frequency

G2B04

When selecting a CW transmitting frequency, what minimum separation should be used to minimize interference to stations on adjacent frequencies?

150 to 500 Hz

G2B05

What is the customary minimum frequency separation between SSB signals under normal conditions?

Approximately 3 kHz

G2B06

What is a practical way to avoid harmful interference on an apparently clear frequency before calling CQ on CW or phone?

Send "QRL?" on CW, followed by your call sign; or, if using phone, ask if the frequency is in use, followed by your call sign

QRL *Are you busy? I am busy, please do not interfere.*

See list of common Q signals on pages 101-103 in the appendix.

G2B07

Which of the following complies with good amateur practice when choosing a frequency on which to initiate a call?

Follow the voluntary band plan for the operating mode you intend to use

See band plan on page 7

G2B08

What is the "DX window" in a voluntary band plan?

A portion of the band that should not be used for contacts between stations within the 48 contiguous United States

Frequencies	Segment/Net name	Mode	Comments	Website
1830-1840	DX Window	CW	Intercontinental DX window	
1840-1850	DX Window	SSB	<i>Intercontinental DX window</i>	
3500-3510	DX Window	CW	CW	
3590	DX Window	Digital	RTTY	
3790-3800	DX Window	SSB	SSB	
7000-7010	DX Window	CW	CW	
7040	DX Window	Digital	RTTY	
14000-14025	DX Window	CW	CW	
21000-21025	DX Window	CW	CW	
28000-28025	DX Window	CW	CW	
50.1-50.125	DX Window	Other	Mixed CW/SSB	
50.11	DX Window	Other	<i>DX Calling Frequency. CW/SSB. Once you establish a QSO, please move off this frequency.</i>	
51-51.1	DX Window	CW	Pacific DX	

G2B09 [97.407(a)]

Who may be the control operator of an amateur station transmitting in RACES to assist relief operations during a disaster?

Only a person holding an FCC issued amateur operator license



RACES volunteer operators are Licensed Radio Amateurs:

- *Certified by a civil defense agency*
- *Able to communicate on Amateur Radio frequencies during drills, exercises and emergencies*
- *Activated by local, county and state jurisdictions and are the only Amateur Radio operators authorized to transmit during declared emergencies when the President of the United States specifically invokes the War Powers Act.*

G2B10 [97.407(b)]

When may the FCC restrict normal frequency operations of amateur stations participating in RACES?

When the President's War Emergency Powers have been invoked



While the Amateur Radio Service will not automatically be shut down if the President invokes the War Powers Act, Amateur Radio licensees must continue to observe any directives the FCC may issue in the interests of national security and of making spectrum available for government use.

G2B11 [97.405]

What frequency should be used to send a distress call?

Whichever frequency has the best chance of communicating the distress message

G2B12 [97.405(b)]

When is an amateur station allowed to use any means at its disposal to assist another station in distress?

At any time during an actual emergency

G2C - CW operating procedures and procedural signals; Q signals and common abbreviations: full break in

For questions G2C01, G2C02, G2C04, G2C09 thru G2C11 and thru G2C11 see the list of common Q signals on pages 101 to 103 in the appendix.

G2C01

Which of the following describes full break-in telegraphy (QSK)?

Transmitting stations can receive between code characters and elements

QSK	<i>Can you hear me between you signals and if so can I break in on your transmission? I can hear you between my signals, break in on my transmission.</i>
------------	---

G2C02

What should you do if a CW station sends "QRS"?

Send slower

QRS	<i>Shall I send more slowly? Send more slowly (___ WPM.).</i>
------------	---

G2C03

What does it mean when a CW operator sends "KN" at the end of a transmission?

Listening only for a specific station or stations

Procedural Signals (Prosign's) for Morse Code

*C Q - Calling any station (does any ham *not* know this one?)*

AR - "+" over, end of message

K - go, invite any station to transmit

KN - "STATION CALL" go only, invite a specific station to transmit

BK - invite receiving station to transmit

R - all received OK

AS - please stand by

SK - end of contact (sent before call)

L - going off the air (clear)

G2C04

What does the Q signal "QRL?" mean?

"Are you busy?", or "Is this frequency in use?"

<i>QRL</i>	<i>Are you busy? I am busy, please do not interfere.</i>
------------	--

G2C05

What is the best speed to use when answering a CQ in Morse code?

The speed at which the CQ was sent

G2C06

What does the term "zero beat" mean in CW operation?

Matching your transmit frequency to the frequency of a received signal.

G2C07

When sending CW, what does a "C" mean when added to the RST report?

Chirpy or unstable signal

R = READABILITY

1 -- Unreadable

2 -- Barely readable, occasional words distinguishable

3 -- Readable with considerable difficulty

4 -- Readable with practically no difficulty

5 -- Perfectly readable

S = SIGNAL STRENGTH

1 -- Faint signals, barely perceptible

2 -- Very weak signals

3 -- Weak signals

4 -- Fair signals

5 -- Fairly good signals

6 -- Good signals

7 -- Moderately strong signals

8 -- Strong signals

9 -- Extremely strong signals

T = TONE

1 -- Sixty cycle a.c. or less, very rough and broad

2 -- Very rough a.c. , very harsh and broad

3 -- Rough a.c. tone, rectified but not filtered

4 -- Rough note, some trace of filtering

5 -- Filtered rectified a.c. but strongly ripple-modulated

6 -- Filtered tone, definite trace of ripple modulation

- 7 -- Near pure tone, trace of ripple modulation
- 8 -- Near perfect tone, slight trace of modulation
- 9 -- Perfect tone, no trace of ripple or modulation of any kind

C- Chirpy signal (refers to CW only)

G2C08

What prosign is sent to indicate the end of a formal message when using CW?

AR

See answer for G2C03 for list of prosign's

G2C09

What does the Q signal "QSL" mean?

I acknowledge receipt

QSL	<i>Can you acknowledge receipt? I am acknowledging receipt.</i>
------------	---

G2C10

What does the Q signal "QRN" mean?

I am troubled by static

QRN	<i>Are you troubled by static? I am troubled by static.</i>
------------	---

G2C11

What does the Q signal "QRV" mean?

I am ready to receive messages

QRV	<i>Are you ready? I am ready.</i>
------------	-----------------------------------

G2D - Amateur Auxiliary; minimizing interference; HF operations

G2D01

What is the Amateur Auxiliary to the FCC?

Amateur volunteers who are formally enlisted to monitor the airwaves for rules violations

G2D02

Which of the following are objectives of the Amateur Auxiliary?

To encourage self-regulation and compliance with the rules by radio amateur operators

G2D03

What skills learned during hidden transmitter hunts are of help to the Amateur Auxiliary?

Direction finding used to locate stations violating FCC Rules

This skill is also used to locate sources of intentional and unintentional interference.

G2D04

Which of the following describes an azimuthal projection map?

A map that shows true bearings and distances from a particular location

The definition of AZIMUTHAL EQUIDISTANT PROJECTION is a map projection of the surface of the earth so centered at any given point that a straight line radiating from the center to any other point represents the shortest distance and can be measured to scale. It places your location in the center of the Global map.

G2D05 [97.111(a)(1)]

When is it permissible to communicate with amateur stations in countries outside the areas administered by the Federal Communications Commission?

When the contact is with amateurs in any country except those whose administrations have notified the ITU that they object to such communications

G2D06

How is a directional antenna pointed when making a "long-path" contact with another station?

180 degrees from its short-path heading



G2D07 [97.303(i)]

Which of the following is required by the FCC rules when operating in the 60-meter band?

If you are using other than a dipole antenna, you must keep a record of the gain of your antenna

G2D08

What is a reason why many amateurs keep a station log?

To help with a reply if the FCC requests information

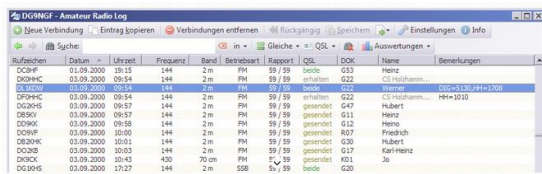
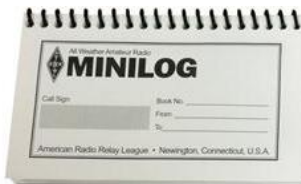

G2D09

What information is traditionally contained in a station log?

- A. Date and time of contact**
- B. Band and/or frequency of the contact**
- C. Call sign of station contacted and the signal report given**
- D. All of these choices are correct**

STATION CALLSIGN: _____ HF Log Sheet PAGE ____ OF ____.

DATE	UTC		FREQ	MODE	POWER	CALLSIGN	QTH	RST		
	ON	OFF						SENT	RCVD	
										1
COMMENTS										
										2
COMMENTS										
										3
COMMENTS										

G2D10

What is QRP operation?

Low power transmit operation

QRP *Shall I decrease power? Decrease power.*

See list of common Q signals on page 106 to 109 in the appendix

G2D11

Which HF antenna would be the best to use for minimizing interference?

A directional antenna



G2E - Digital operating: procedures, procedural signals and common abbreviations

G2E01

Which mode is normally used when sending an RTTY signal via AFSK with an SSB transmitter?

LSB

RTTY is Radio Teletype and AFSK is audio frequency shift keying. A digital one or zero is sent as one of two different audio tones.

G2E02

How can a PACTOR modem or controller be used to determine if the channel is in use by other PACTOR stations?

Put the modem or controller in a mode which allows monitoring communications without a Connection.

PACTOR is a radio modulation mode used by amateur radio operators, marine radio stations, and radio stations in isolated areas to send and receive digital information via radio. A robust network of PACTOR stations has been established to relay data between radio stations and the Internet, extending Internet access to sea based and other isolated users. PACTOR utilizes an almost ideal combination of simple FSK modulation, and the ARQ protocol for robust error detection and data throughput. Generational improvements to PACTOR include PACTOR II, PACTOR III, and PACTOR IV which are capable of higher speed transmission. PACTOR modes subsequent to level 1 (P1) are not open source and therefore cannot be decoded by anyone who hasn't invested in a proprietary modem.

G2E03

What symptoms may result from other signals interfering with a PACTOR or WINMOR transmission?

- A. Frequent retries or timeouts**
- B. Long pauses in message transmission**
- C. Failure to establish a connection between stations**
- D. All of these choices are correct**

G2E04

What segment of the 20-meter band is most often used for digital transmissions?

14.070 - 14.100 MHz

G2E06

What is the most common frequency shift for RTTY emissions in the amateur HF bands?

170 Hz

G2E07

What segment of the 80-meter band is most commonly used for digital transmissions?

3570 – 3600 kHz

See US Amateur Radio Band Plan on page 7.

G2E08

In what segment of the 20-meter band are most PSK31 operations commonly found?

Below the RTTY segment, near 14.070 MHz

G2E09

How do you join a contact between two stations using the PACTOR protocol?

Joining an existing contact is not possible; PACTOR connections are limited to two stations

G2E10

Which of the following is a way to establish contact with a digital messaging system gateway station?

Transmit a connect message on the station's published frequency

Gateway stations are listed at <http://www2.winlink.org:8081/GatewayChannels.aspx>.

G2E11

What is indicated on a waterfall display by one or more vertical lines adjacent to a PSK31 signal?

Overmodulation

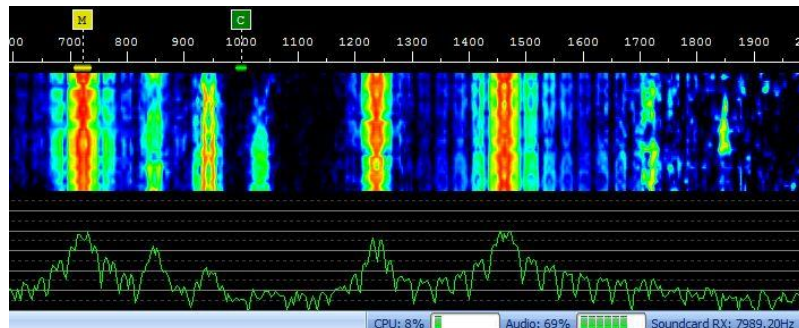

G2E12

Which of the following describes a waterfall display?

Frequency is horizontal, signal strength is intensity, time is vertical

G2E13

Which communication system sometimes uses the Internet to transfer messages?

Winlink

Winlink, also known as the Winlink 2000 Network, is a worldwide radio messaging system that mixes internet technology and appropriate Amateur Radio RF technologies. The system provides radio interconnection services including: email with attachments, position reporting, graphic and text weather bulletins, emergency/disaster relief communications, and message relay. The system is built and administered by volunteers without pecuniary interests. Winlink 2000 is a project of the Amateur Radio Safety Foundation, Inc. (ARSAFI).

G2E14

What could be wrong if you cannot decode an RTTY or other FSK signal even though it is apparently tuned in properly?

- A. The mark and space frequencies may be reversed**
- B. You may have selected the wrong baud rate**
- C. You may be listening on the wrong sideband**
- D. All of these choices are correct**

G2E15

What is the standard sideband used to generate a JT65 or JT9 digital signal when using AFSK in any amateur band?

USB

JT65 is a digital protocol intended for Amateur Radio communication with extremely weak signals. It was designed to optimize Earth-Moon-Earth (EME) contacts on the VHF bands, and conforms efficiently to the established standards and procedures for such QSOs. JT65 includes error-correcting features that make it very robust, even with signals much too weak to be heard. Since this is a VHF communication protocol and therefore greater than 10 MHz it would use USB.

Recently JT65 has been adapted to the HF bands

SUBELEMENT G3 - RADIO WAVE PROPAGATION

[3 Exam Questions - 3 Groups]

G3A - Sunspots and solar radiation; ionospheric disturbances; propagation forecasting and indices

G3A01

What is the significance of the sunspot number with regard to HF propagation?

Higher sunspot numbers generally indicate a greater probability of good propagation at higher frequencies



Scientists track solar cycles by counting sunspots -cool planet-sized areas on the Sun where intense magnetic loops poke through the star's visible surface.

Counting sunspots is not as straightforward as it sounds. Suppose you looked at the Sun through a pair of (properly filtered) low power binoculars -- you might be able to see two or three large spots. An observer peering through a high-powered telescope might see 10 or 20. A powerful space-based observatory could see even more -- say, 50 to 100. Which is the correct sunspot number?

There are two official sunspot numbers in common use. The first, the daily "Boulder Sunspot Number," is computed by the NOAA Space Environment Center using a formula devised by Rudolph Wolf in 1848:

The Boulder number (reported daily on SpaceWeather.com) is usually about 25% higher than the second official index, the "International Sunspot Number," published daily by the Solar Influences Data Center in Belgium. Both the Boulder and the International numbers are calculated from the same basic formula, but they incorporate data from different observatories.

As a rule of thumb, if you divide either of the official sunspot numbers by 15, you'll get the approximate number of individual sunspots visible on the solar disk if you look at the Sun by projecting its image on a paper plate with a small telescope.

G3A02

What effect does a Sudden Ionospheric Disturbance have on the daytime ionospheric propagation of HF radio waves?

It disrupts signals on lower frequencies more than those on higher frequencies

A Sudden Ionospheric Disturbance (SID) is an abnormally high ionization/plasma density in the D region of the ionosphere caused by a solar flare. The SID results in a sudden increase in radio-wave absorption that is most severe in the upper medium frequency (MF) and lower high frequency (HF) ranges, and as a result often interrupts or interferes with telecommunications systems.

Short wave radio waves (in the HF range) are absorbed by the increased particles in the low altitude ionosphere causing a complete blackout of radio communications. This is called a short wave fading. These fadeouts last for a few minutes to a few hours and are most severe in the equatorial regions where the Sun is most directly overhead. The ionospheric disturbance enhances long wave (VLF)

radio propagation. SIDs are observed and recorded by monitoring the signal strength of a distant VLF transmitter.

G3A03

Approximately how long does it take the increased ultraviolet and X-ray radiation from solar flares to affect radio propagation on the Earth?

8 minutes

G3A04

Which of the following are **least reliable** for long distance communications during periods of low solar activity?

15 meters, 12 meters and 10 meters

G3A05

What is the solar flux index?

A measure of solar radiation at 10.7 centimeters wavelength

The 10.7cm frequency is Speed of Light divided by wavelength or $300 \div 0.107$ or 2,800 MHz or 2.8 GHz.

G3A06

What is a geomagnetic storm?

A temporary disturbance in the Earth's magnetosphere

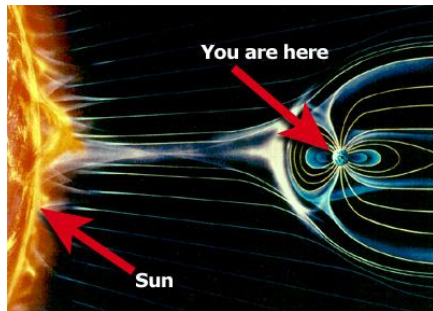

A geomagnetic storm is a temporary disturbance of the Earth's magnetosphere caused by a solar wind shock wave and/or cloud of magnetic field which interacts with the Earth's magnetic field. The increase in the solar wind pressure initially compresses the magnetosphere and the solar wind's magnetic field interacts with the Earth's magnetic field and transfers an increased energy into the magnetosphere. Both interactions cause an increase in movement of plasma through the magnetosphere (driven by increased electric fields inside the magnetosphere) and an increase in electric current in the magnetosphere and ionosphere.

G3A07

At what point in the solar cycle does the 20-meter band usually support worldwide propagation during daylight hours?

At any point in the solar cycle

G3A08

Which of the following effects can a geomagnetic storm have on radio propagation?

Degraded high-latitude HF propagation

G3A09

What effect does a high sunspot number have on radio communications?

Long-distance communication in the upper HF and lower VHF range is enhanced

G3A10

What causes HF propagation conditions to vary periodically in a 28 day cycle?

The Sun's rotation on its axis

G3A11

Approximately how long is the typical sunspot cycle?

11 years

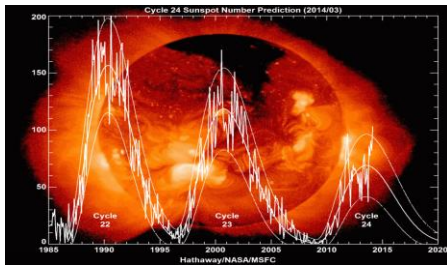

G3A12

What does the K-index indicate?

The short term stability of the Earth's magnetic field

G3A13

What does the A-index indicate?

The long term stability of the Earth's geomagnetic field

G3A14

How are radio communications usually affected by the charged particles that reach the Earth from solar coronal holes?

HF communications are disturbed

G3A15

How long does it take charged particles from coronal mass ejections to affect radio propagation on the Earth?

20 to 40 hours



G3A16

What is a possible benefit to radio communications resulting from periods of high geomagnetic activity?

Auroras that can reflect VHF signals

G3B - Maximum Usable Frequency; Lowest Usable Frequency; propagation

G3B01

How might a sky-wave signal sound if it arrives at your receiver by both short path and long path propagation?

A well-defined echo might be heard



G3B02

Which of the following is a good indicator of the possibility of sky-wave propagation on the 6-meter band?

Short skip sky-wave propagation on the 10-meter band

G3B03

Which of the following applies when selecting a frequency for lowest attenuation when transmitting on HF?

Select a frequency just below the MUF

MUF is the Maximum Usable Frequency for communications between two points.

G3B04

What is a reliable way to determine if the MUF is high enough to support skip propagation between your station and a distant location on frequencies between 14 and 30 MHz?

Listen for signals from an international beacon in the frequency range you plan to use.

There are beacons at 14.100, 18.110, 21.150, 24.930, and 28.200 MHz.

G3B05

What usually happens to radio waves with frequencies below the MUF and above the LUF when they are sent into the ionosphere?

They are bent back to the Earth

LUF is the Lowest Usable Frequency for communications between two points.

G3B06

What usually happens to radio waves with frequencies below the LUF?

They are completely absorbed by the ionosphere

G3B07

What does LUF stand for?

The Lowest Usable Frequency for communications between two points

G3B08

What does MUF stand for?

The Maximum Usable Frequency for communications between two points

G3B09

What is the approximate maximum distance along the Earth's surface that is normally covered in one hop using the F2 region?

2,500 miles

G3B10 (B)

What is the approximate maximum distance along the Earth's surface that is normally covered in one hop using the E region?

1,200 miles

G3B11

What happens to HF propagation when the LUF exceeds the MUF?

No HF radio frequency will support ordinary sky-wave communications over the path

G3B12 (D)

What factor or factors affect the MUF?

- A. Path distance and location**
- B. Time of day and season**
- C. Solar radiation and ionospheric disturbances**
- D. All of these choices are correct**

G3C - Ionospheric layers; critical angle and frequency; HF scatter; Near Vertical Incidence Sky-wave

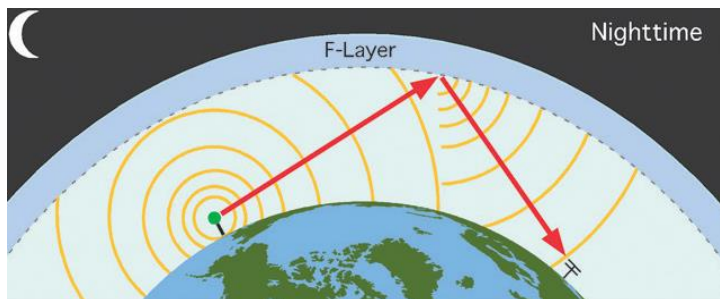
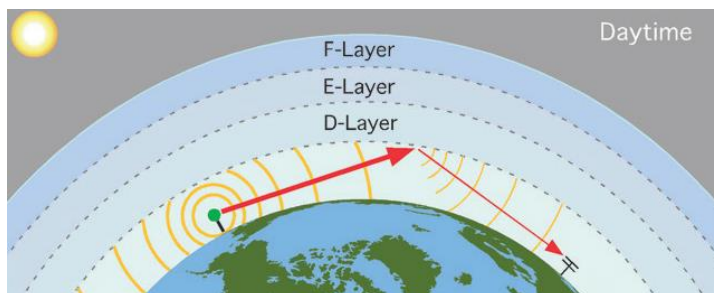

G3C01

Which ionospheric layer is closest to the surface of the Earth?

The D layer

G3C02

Where on the Earth do ionospheric layers reach their maximum height?

Where the Sun is overhead

G3C03

Why is the F2 region mainly responsible for the longest distance radio wave propagation?

Because it is the highest ionospheric region

G3C04

What does the term "critical angle" mean as used in radio wave propagation?

The highest takeoff angle that will return a radio wave to the Earth under specific ionospheric conditions

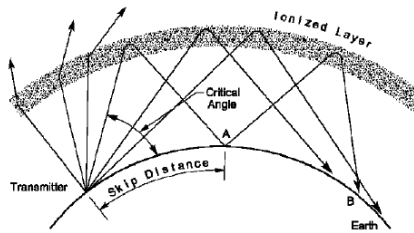

G3C05

Why is long distance communication on the 40-meter, 60-meter, 80-meter and 160-meter bands more difficult during the day?

The D layer absorbs signals at these frequencies during daylight hours

G3C06

What is a characteristic of HF scatter signals?

They have a wavering sound

G3C07

What makes HF scatter signals often sound distorted?

Energy is scattered into the skip zone through several different radio wave paths

G3C08

Why are HF scatter signals in the skip zone usually weak?

Only a small part of the signal energy is scattered into the skip zone

G3C09

What type of radio wave propagation allows a signal to be detected at a distance too far for ground wave propagation but too near for normal sky-wave propagation?

Scatter

G3C10

Which of the following might be an indication that signals heard on the HF bands are being received via scatter propagation?

The signal is heard on a frequency above the Maximum Usable Frequency

G3C11

Which of the following antenna types will be most effective for skip communications on 40-meters during the day?

A horizontal dipole placed between 1/8 and 1/4 wavelength above the ground

G3C12

Which ionospheric layer is the most absorbent of long skip signals during daylight hours on frequencies below 10 MHz?

The D layer

G3C13

What is Near Vertical Incidence Sky-wave (NVIS) propagation?

Short distance MF or HF propagation using high elevation angles

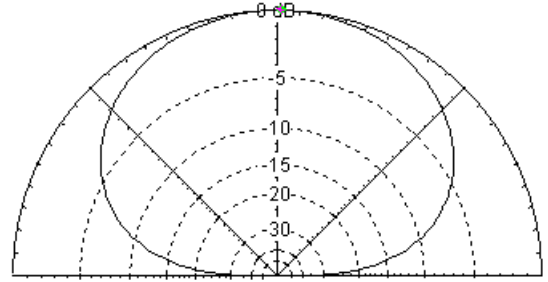
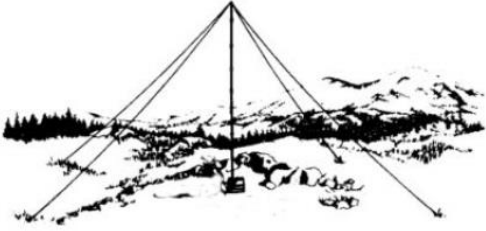

SUBELEMENT G4 - AMATEUR RADIO PRACTICES

[5 Exam Questions - 5 groups]

G4A – Station Operation and set up

G4A01

What is the purpose of the "notch filter" found on many HF transceivers?

To reduce interference from carriers in the receiver passband

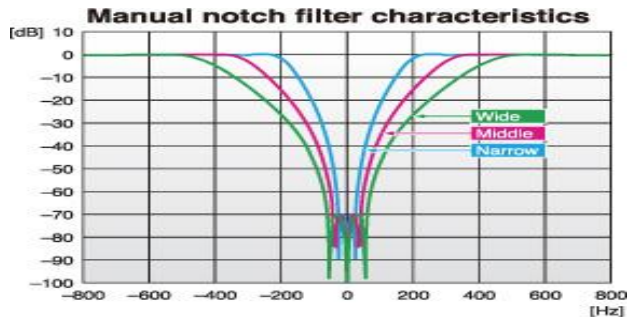

G4A02

What is one advantage of selecting the opposite or "reverse" sideband when receiving CW signals on a typical HF transceiver?

It may be possible to reduce or eliminate interference from other signals

G4A03

What is normally meant by operating a transceiver in "split" mode?

The transceiver is set to different transmit and receive frequencies

G4A04

What reading on the plate current meter of a vacuum tube RF power amplifier indicates correct adjustment of the plate tuning control?

A pronounced dip

The dip occurs because the output circuit is resonant, and some of the current is regenerated in the tank circuit with less coming from the power supply.

G4A05

What is a reason to use Automatic Level Control (ALC) with an RF power amplifier?

To reduce distortion due to excessive drive

G4A06

What type of device is often used to match transmitter output impedance to an impedance not equal to 50 ohms?

Antenna coupler or antenna tuner



G4A07

What condition can lead to permanent damage to a solid-state RF power amplifier?

Excessive drive power

G4A08

What is the correct adjustment for the load or coupling control of a vacuum tube RF power amplifier?

Maximum power output without exceeding maximum allowable plate current

G4A09

Why is a time delay sometimes included in a transmitter keying circuit?

To allow time for transmit-receive changeover operations to complete properly before RF output is allowed

G4A10

What is the purpose of an electronic keyer?

Automatic generation of strings of dots and dashes for CW operation

G4A11

Which of the following is a use for the IF shift control on a receiver?

To avoid interference from stations very close to the receive frequency

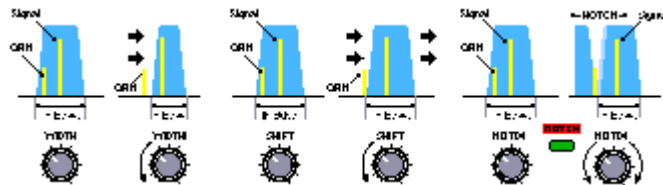

G4A12

Which of the following is a common use for the dual VFO feature on a transceiver?

To permit monitoring of two different frequencies

G4A13 (A)

What is one reason to use the attenuator function that is present on many HF transceivers?

To reduce signal overload due to strong incoming signals

G4A14

What is likely to happen if a transceiver's ALC system is not set properly when transmitting AFSK signals with the radio using single sideband mode?

Improper action of ALC distorts the signal and can cause spurious emissions

G4A15

Which of the following can be a symptom of transmitted RF being picked up by an audio cable carrying AFSK data signals between a computer and a transceiver?

- A. The VOX circuit does not un-key the transmitter**
- B. The transmitter signal is distorted**
- C. Frequent connection timeouts**
- D. All of these choices are correct**

G4B - Test and monitoring equipment; two-tone test

G4B01

What item of test equipment contains horizontal and vertical channel amplifiers?

An oscilloscope

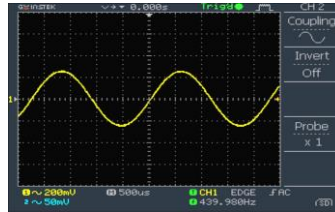
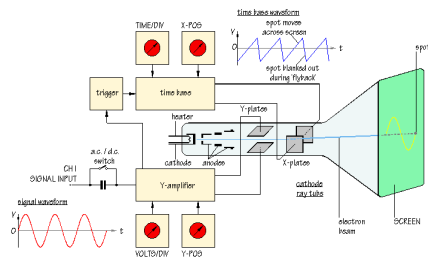

G4B02

Which of the following is an advantage of an oscilloscope versus a digital voltmeter?

Complex waveforms can be measured

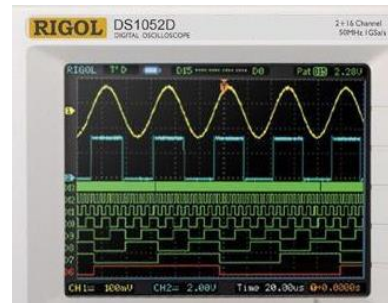
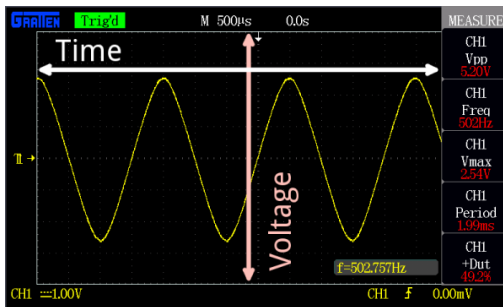

G4B03

Which of the following is the best instrument to use when checking the keying waveform of a CW transmitter?

An oscilloscope

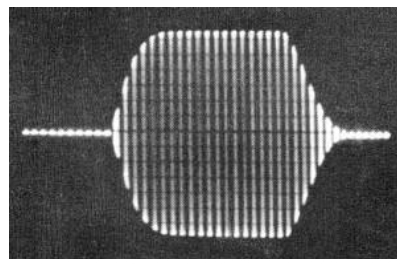

It is desired that the keying waveform have slow rise and fall times as shown above

G4B04

What signal source is connected to the vertical input of an oscilloscope when checking the RF envelope pattern of a transmitted signal?

The attenuated RF output of the transmitter

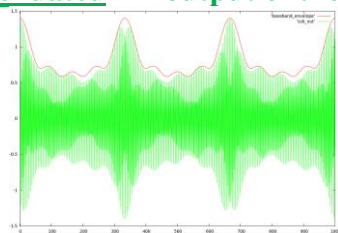

Too much power applied to the oscilloscope vertical input will cause permanent damage to the oscilloscope. Power should be limited to a few milliwatts.

G4B05

Why is high input impedance desirable for a voltmeter?

It decreases the loading on circuits being measured

G4B06

What is an advantage of a digital voltmeter as compared to an analog voltmeter?

Better precision for most uses



G4B07

What signals are used to conduct a two-tone test?

Two non-harmonically related audio signals

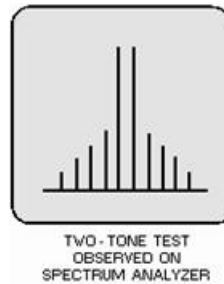
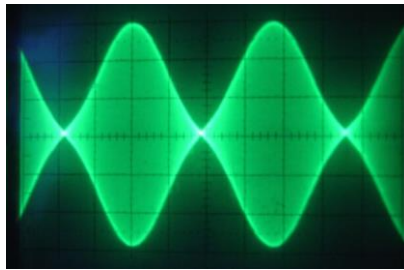

To perform this test you apply the two non-harmonically related test tones are set to the same level and then combined and fed into the microphone jack. Either tone by itself will generate a carrier at the transceiver set frequency + or - the tone frequency (upper or lower sideband). The output of the transmitter is sampled and applied to the vertical input of an oscilloscope. When both tones are applied simultaneously they will beat against each other and generate a modulated carrier waveform at the difference frequency between the two audio signals as shown above. Any distortion in the sinusoidal shape of the beat frequency will be caused by non-linearity. This test can also be performed with a spectrum analyzer.

G4B08

Which of the following instruments may be used to monitor relative RF output when making antenna and transmitter adjustments?

A field strength meter

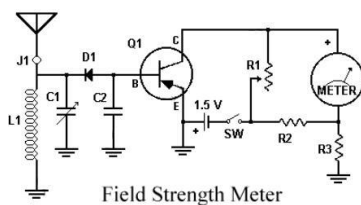

G4B09

Which of the following can be determined with a field strength meter?

The radiation pattern of an antenna

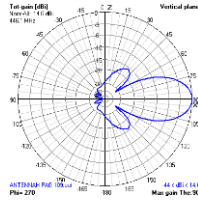

G4B10

Which of the following can be determined with a directional wattmeter?

Standing wave ratio



$$VSWR = \frac{\sqrt{1 + \frac{\text{Power Reflected}}{\text{Power Forward}}}}{\sqrt{1 - \frac{\text{Power Reflected}}{\text{Power Forward}}}}$$

G4B11

Which of the following must be connected to an antenna analyzer when it is being used for SWR measurements?

Antenna and feed line



Be sure to discharge (short the center conductor to the connector shell) before attaching any cable to an antenna analyzer to prevent a static electricity charge from damaging the analyzer.

G4B12

What problem can occur when making measurements on an antenna system with an antenna analyzer?

Strong signals from nearby transmitters can affect the accuracy of measurements

G4B13

What is a use for an antenna analyzer other than measuring the SWR of an antenna system?

Determining the impedance of an unknown or unmarked coaxial cable

G4B14

What is an instance in which the use of an instrument with analog readout may be preferred over an instrument with a digital readout?

When adjusting tuned circuits

When adjustments are made for minimum or maximum it is easier to see the peak or minimum on an analog meter.

G4B15

What type of transmitter performance does a two-tone test analyze?

Linearity

See answer to question G4B07 above.

G4C - Interference with consumer electronics; grounding; DSP

G4C01

Which of the following might be useful in reducing RF interference to audio frequency devices?

Bypass capacitor

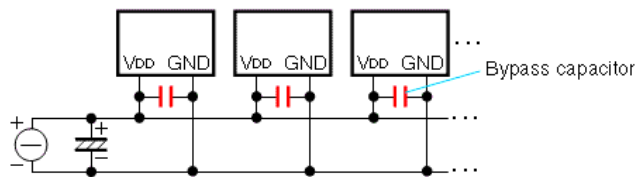

G4C02

Which of the following could be a cause of interference covering a wide range of frequencies?

Arcing at a poor electrical connection

G4C03

What sound is heard from an audio device or telephone if there is interference from a nearby single sideband phone transmitter?

Distorted speech

G4C04

What is the effect on an audio device or telephone system if there is interference from a nearby CW transmitter?

On-and-off humming or clicking

G4C05

What might be the problem if you receive an RF burn when touching your equipment while transmitting on an HF band, assuming the equipment is connected to a ground rod?

The ground wire has high impedance on that frequency

G4C06

What effect can be caused by a resonant ground connection?

High RF voltages on the enclosures of station equipment

G4C07

What is one good way to avoid unwanted effects of stray RF energy in an amateur station?

Connect all equipment grounds together

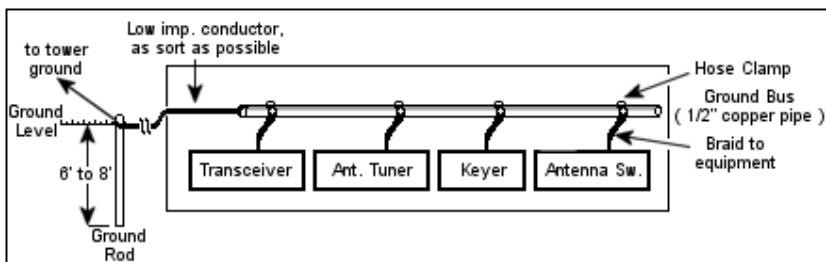

G4C08

Which of the following would reduce RF interference caused by common-mode current on an audio cable?

Placing a ferrite choke around the cable

The Ferrite chokes act like a series inductor to common mode current.



G4C09

How can a ground loop be avoided?

Connect all ground conductors to a single point

G4C10

What could be a symptom of a ground loop somewhere in your station?

You receive reports of "hum" on your station's transmitted signal

G4C11

Which of the following is a function of a digital signal processor?

To remove noise from received signals

G4C12

Which of the following is an advantage of a receiver DSP IF filter as compared to an analog filter?

A wide range of filter bandwidths and shapes can be created

G4C13

Which of the following can perform automatic notching of interfering carriers?

A Digital Signal Processor (DSP) filter

G4D - Speech processors; S meters; sideband operation near band edges

G4D01

What is the purpose of a speech processor as used in a modern transceiver?

Increase the intelligibility of transmitted phone signals during poor conditions

G4D02

Which of the following describes how a speech processor affects a transmitted single sideband phone signal?

It increases average power

G4D03 (D)

Which of the following can be the result of an incorrectly adjusted speech processor?

- A. Distorted speech
- B. Splatter
- C. Excessive background pickup
- D. All of these choices are correct

Brief Decibel (dB) Tutorial

Many times in electronics is necessary to compare values that are quite far apart. To make this comparison we use a term called the Decibel or dB. If we had a transmitter with a 1,000 watts of output power and a receiver with 0.01 μwatt sensitivity the ratio between these two values would be 100 Billion to 1, which is a difficult number to work with. By expressing the value as an exponent we can make these large ratios more manageable (in the above 100 billion to one it would be 110 dB). Using dB values we can calculate the effect of gains and losses in networks. The dB value for power in a network can be calculated using the following equation:

$$dB = 10 (\log (\text{power } 2 / \text{Power } 1)) \quad (\text{use the base 10 logarithm key not natural log}(e) \text{ key})$$

Examples:

What is the ratio in dB between power levels of 50 watts with 100 watts?

$$dB = 10 (\log (P2/ P1)) \text{ or } dB= 10(\log(100/50)) \text{ or } dB= 10 (\text{Log}(2)) \text{ or } dB=10(0.301) \text{ or } dB =3.01$$

What is the ratio in dB between the power levels of 100 watts with 50 watts?

$$dB =10 (\log (P2/ P1)) \text{ or } dB=10(\log(50/100)) \text{ or } dB=10 (\text{Log}(.5)) \text{ or } dB=10(-0.301) \text{ or } dB =-3.01$$

What is the ratio in dB between power levels of 85 watts with 13 watts?

$$dB =10 (\log (P2/ P1)) \text{ or } dB=10(\log(85/13)) \text{ or } dB=10 (\text{Log}(6.53)) \text{ or } dB=10(0.815) \text{ or } dB =8.15$$

To find a ratio from a dB value take the dB value, divide it by 10 then raise ten to that power (a log is an exponent of 10 that is why they are called base 10 logarithms).

$$\text{Ratio} = 10^{(dB/10)}$$

Examples:

What is the power ratio expressed by 15 dB?

$$\text{Ratio} = 10^{(dB/10)} \text{ or } \text{Ratio} = 10^{(15/10)} \text{ or } \text{Ratio} = 10^{(1.5)} \text{ Ratio} = 31.62$$

What is the power ratio expressed by 2dB?

$$\text{Ratio} = 10^{(dB/10)} \text{ or } \text{Ratio} = 10^{(2/10)} \text{ or } \text{Ratio} = 10^{(.200)} \text{ Ratio} = 1.585$$

To answer questions on the general exam you can remember the above equations and calculations or remember these few simple dB power ratios that will get you through all the exam questions.

Gain (+)	dB	Loss (-)
x ~1.2	1	~80%
x 1.6	2	63%
x 2	3	50%
x 10	10	10%

G4D04

What does an S meter measure?

Received signal strength

Note that the readings from S1 to S9 are “not” in dB. The readings above S9 are given in dB above S9. Each S unit represents approx. a 6 dB voltage change (or a 3dB power change). An S9 signal is typically -73dBm (50µv).

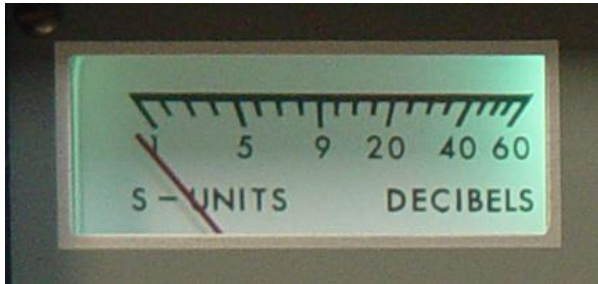

G4D05

How does a signal that reads 20 dB over S9 compare to one that reads S9 on a receiver, assuming a properly calibrated S meter?

It is 100 times more powerful

10 dB would be 10 times more powerful therefore 20 dB would be 10 times the 10 dB or 10 x 10 or 100.

G4D06

Where is an S meter found?

In a receiver

G4D07

How much must the power output of a transmitter be raised to change the S meter reading on a distant receiver from S8 to S9?

Approximately 4 times

Note that the readings from S1 to S9 are not in dB. The readings above S9 are given in dB above S9. Each S unit represents approx. a 6 dB change (4 times power change).

G4D08

What frequency range is occupied by a 3 kHz LSB signal when the displayed carrier frequency is set to 7.178 MHz?

7.175 to 7.178 MHz

The frequency occupied by a SSB signal is approximately 3 kHz. For a lower sideband signal the spectrum occupied will be from 3 kHz below the dial set frequency to the dial set frequency. In this case frequency occupied would be:

The carrier frequency – 3 kHz (for lower SSB) set the carrier set frequency to:

7.178 - .003 to 7.178 or 7.175 to 7.178 MHz

G4D09

What frequency range is occupied by a 3 kHz USB signal with the displayed carrier frequency set to 14.347 MHz?

14.347 to 14.350 MHz

The frequency occupied by a SSB signal is approximately 3 kHz. For an upper sideband signal the spectrum occupied will be from the dial set frequency to + 3 kHz above the dial set frequency to the dial set frequency. In this case frequency occupied would be:

Frequency range occupied would be from the carrier set frequency of 14.347 MHz to the carrier set frequency + 3 kHz (for USB)

14.347 MHz to 14.347 MHz +.003 MHz or 14.347 to 14.350 MHz

G4D10

How close to the lower edge of the 40-meter General Class phone segment should your displayed carrier frequency be when using 3 kHz wide LSB?

At least 3 kHz above the edge of the segment

G4D11

How close to the upper edge of the 20-meter General Class band should your displayed carrier frequency be when using 3 kHz wide USB?

At least 3 kHz below the edge of the band

G4E - HF mobile radio installations; emergency and battery powered operation

G4E01

What is the purpose of a capacitance hat on a mobile antenna?

To electrically lengthen a physically short antenna

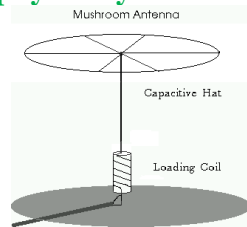

G4E02

What is the purpose of a corona ball on a HF mobile antenna?

To reduce high voltage discharge from the tip of the antenna

G4E03

Which of the following direct, fused power connections would be the best for a 100 watt HF mobile installation?

To the battery using heavy gauge wire

The both leads, negative and positive, should be connected directly to the battery terminals with fuses at the battery ends of the cables.

G4E04

Why is it best NOT to draw the DC power for a 100 watt HF transceiver from a vehicle's auxiliary power socket?

The socket's wiring may be inadequate for the current drawn by the transceiver

Typical 100 watt transceivers draw around 20 to 22 amperes from a 12 volt automobile battery, typical auxiliary power sockets are rated at approximately 10 amperes.

G4E05

Which of the following most limits the effectiveness of an HF mobile transceiver operating in the 75-meter band?

The antenna system

It is not possible to put a mobile full 1/4 wavelength antenna for 75 meters on a vehicle. Any mobile antenna for these frequencies would be inefficient.

G4E06

What is one disadvantage of using a shortened mobile antenna as opposed to a full size antenna?

Operating bandwidth may be very limited

G4E07

Which of the following may cause interference to be heard in the receiver of an HF radio installed in a recent model vehicle?

- A. The battery charging system**
- B. The fuel delivery system (*electric fuel pumps and fuel injectors*)**
- C. The vehicle control computer**
- D. All of these choices are correct**

G4E08

What is the name of the process by which sunlight is changed directly into electricity?

Photovoltaic conversion

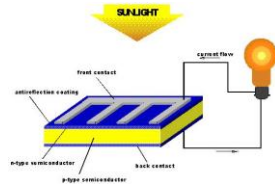

G4E09

What is the approximate open-circuit voltage from a fully illuminated silicon photovoltaic cell?

0.5 VDC

G4E10

What is the reason that a series diode is connected between a solar panel and a storage battery that is being charged by the panel?

The diode prevents self-discharge of the battery though the panel during times of low or no illumination

This is accomplished because diodes allow current to only flow in one direction.

G4E11

Which of the following is a disadvantage of using wind as the primary source of power for an emergency station?

A large energy storage system is needed to supply power when the wind is not blowing



This is an example of a 400 watt 12 volt wind generator.

SUBELEMENT G5 – ELECTRICAL PRINCIPLES

[3 Exam Questions – 3 Groups]

G5A - Reactance; inductance; capacitance; impedance; impedance matching

G5A01

What is impedance?

The opposition to the flow of current in an AC circuit

G5A02 (B)

What is reactance?

Opposition to the flow of alternating current caused by capacitance or inductance

Impedance is the AC resistance of a circuit containing resistance and reactance (capacitive and/or inductive)

Inductive Reactance - $X_L = 2 \pi fL$

Capacitive Reactance - $X_C = 1 \div (2 \pi fC)$

G5A03

Which of the following causes opposition to the flow of alternating current in an inductor?

Reactance

G5A04

Which of the following causes opposition to the flow of alternating current in a capacitor?

Reactance

G5A05

How does an inductor react to AC?

As the frequency of the applied AC increases, the reactance increases

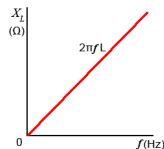

G5A06

How does a capacitor react to AC?

As the frequency of the applied AC increases, the reactance decreases

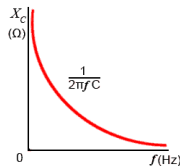

G5A07

What happens when the impedance of an electrical load is equal to the output impedance of a power source, assuming both impedances are resistive?

The source can deliver maximum power to the load

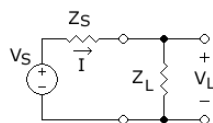

G5A08

Why is impedance matching important?

So the source can deliver maximum power to the load

G5A09

What unit is used to measure reactance?

Ohm

G5A10

What unit is used to measure impedance?

Ohm

G5A11

Which of the following describes one method of impedance matching between two AC circuits?

Insert an LC network between the two circuits

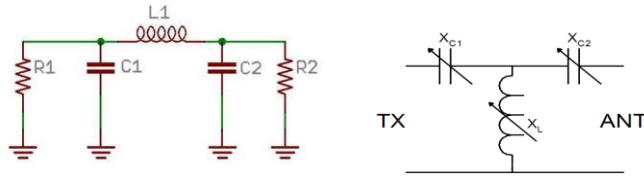

G5A12 (B)

What is one reason to use an impedance matching transformer?

To maximize the transfer of power

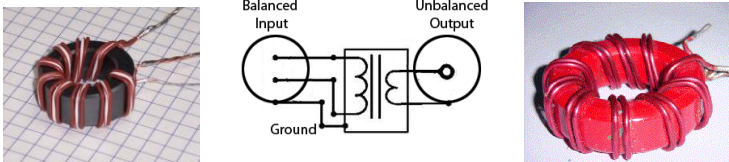

G5A13 (D)

Which of the following devices can be used for impedance matching at radio frequencies?

- A. A transformer**
- B. A Pi-network**
- C. A length of transmission line**
- D. All of these choices are correct**

G5B - The Decibel; current and voltage dividers; electrical power calculations; sine wave root-mean-square (RMS) values; PEP calculations

G5B01

What dB change represents a two-times increase or decrease in power?

Approximately 3 dB

The table below shows common values of dB gain or loss. Multiply the original power by the gain or loss number for the dB of gain or loss.

Gain (+)	dB	Loss (-)
x ~1.2	1	~80%
x 1.6	2	63%
x 2	3	50%
x 10	10	10%

- A two time's increase or decrease in power would result in a change of 3dB.
Ratio = $10^{(dB \div 10)}$ or Ratio = $10^{(3 \div 10)}$ or Ratio = $10^{(0.300)}$ Ratio = 1.995.
- What is the percentage power loss from 1dB transmission line cable loss?
Ratio = $10^{(dB \div 10)}$ or Ratio = $10^{(1 \div 10)}$ or Ratio = 0.794 or a loss of 20.6% (100% - 79.4% = 20.6% loss)

G5B02

How does the total current relate to the individual currents in each branch of a purely resistive parallel circuit?

It equals the sum of the currents through each branch

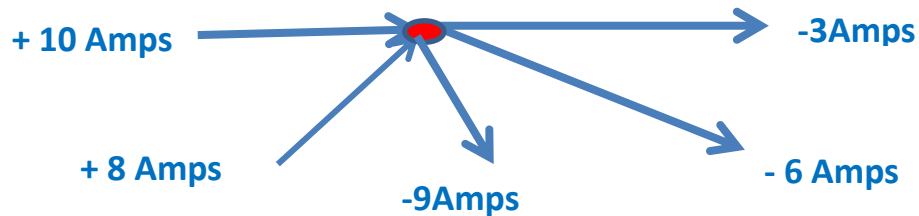

Kirchhoff's law states that the sum of the currents flowing into a circuit node must equal the sum of the currents flowing out of the current node

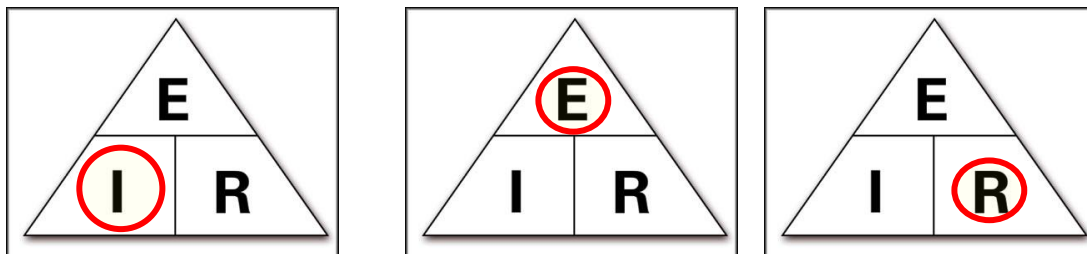

Ohms law states that the current flowing in a circuit is equal to the voltage (E) across the circuit divided by the resistance of the circuit.

If you know two of the variables you can calculate the third. For example the voltage (E) across the circuit is equal to the current through the circuit multiplied by the resistance of the circuit; the resistance of the circuit is equal to the voltage across the circuit divided by the Current through the circuit.

G5B03

How many watts of electrical power are used if 400 VDC is supplied to an 800 ohm load?

200 watts

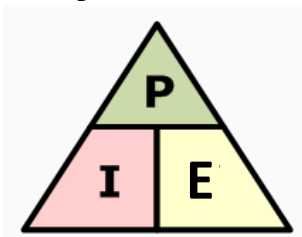

$P = E \times I$, from ohms law we see that $I = E \div R$ so substituting this we get $P = E \times E \div R$ or $P = (400)^2 \div 800$ or $P = 160,000 \div 800$ or $P = 200$ Watts

G5B04

How many watts of electrical power are used by a 12 VDC light bulb that draws 0.2 amperes?

2.4 watts

$$P = E \times I \quad \text{or} \quad P = 12 \times 0.2 \quad \text{or} \quad P = 2.4 \text{ watts}$$

G5B05

How many watts are dissipated when a current of 7.0 milliamperes flows through 1.25 kilohm resistance?

Approximately 61 milliwatts

$$P = I^2 \times R \quad \text{or} \quad P = (0.007)^2 \times 1250 \quad \text{or} \quad P = 0.000049 \times 1250 \quad \text{or} \quad P = 0.0613 \text{ watts}$$

$$0.0613 \text{ watts} = 61.3 \text{ milliwatts}$$

AC Waveform Tutorial

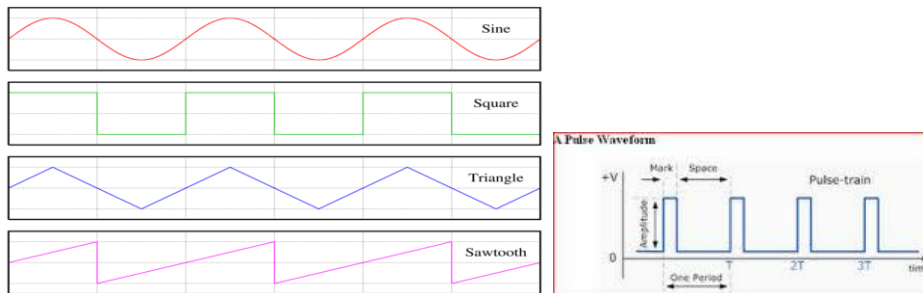

A Sine Wave is a waveform whose amplitude follows a trigonometric Sine function. A pure sine wave contains only the fundamental of its frequency.

A Square Wave is a waveform that alternates abruptly between two voltage levels and stays at each voltage level an equal amount of time. A square wave is made up of a fundamental wave and an infinite number of odd harmonics that add up to make the square wave.

A Pulse Wave is a waveform that alternates abruptly between two voltage levels and stays at each voltage level for an equal or unequal amount of time. When the times are equal we call it a square wave.

A Saw Tooth Wave is a wave with a straight line rise and fall time that is not symmetrical; that is the rise time is longer than the fall time or vice versa. A saw tooth wave is made up of a fundamental and all harmonics.

A Triangle Wave is a special case of the saw tooth wave in that it has equal rise and fall times. The triangle wave has only odd harmonics like the square wave but their amplitudes are far weaker by comparison to the fundamental. .

Characterizing a Sine Waveform

Shown below are two cycles of a sine wave

A sine wave can be displayed on an oscilloscope to determine its frequency by dividing the time for one cycle into 1.00.

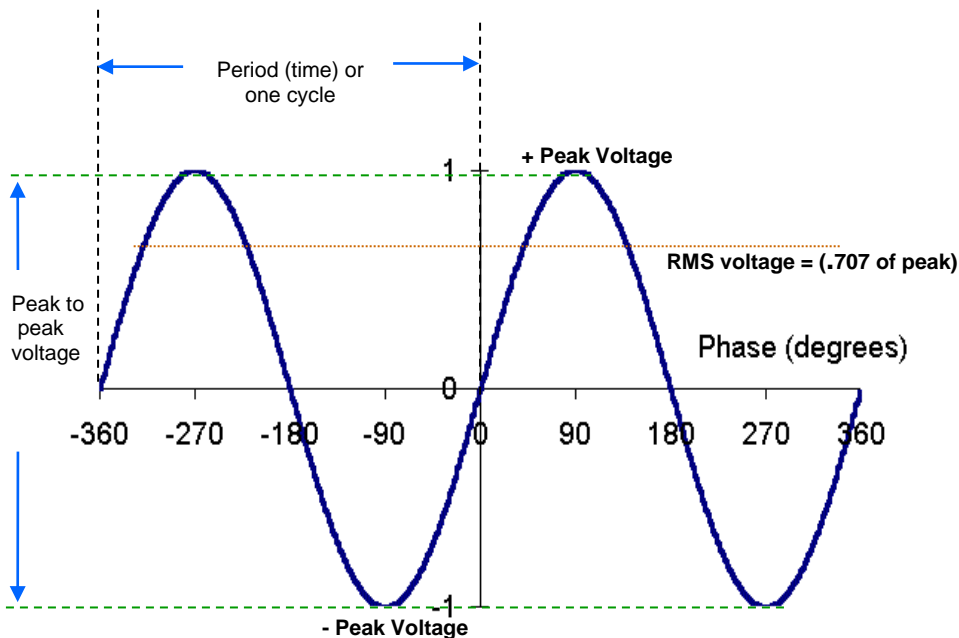

Examples:

What is the frequency of a sine wave with a 10 ms period for one cycle?

$$F = 1 \div \text{time} \quad F = 1 \div .010 \quad F = 100 \text{ Hz}$$

What is the frequency of a sine wave with a 1 μs period for one cycle?

$$F = 1 \div \text{time} \quad F = 1 \div 0.000001 \quad F = 1 \text{ MHz}$$

What is the frequency of a sine wave with a 15 μs period for one cycle?

$$F = 1 \div \text{time} \quad F = 1 \div 0.000015 \quad F = 66.667 \text{ kHz}$$

What is the frequency of a sine wave with a 16.66 millisecond period for one cycle?

$$F = 1 \div \text{time} \quad F = 1 \div 0.016.666 \quad F = 60.02 \text{ Hz}$$

The RMS (Root Mean Square) value for a sine wave is the value of an equivalent DC voltage required to generate the same amount of power or heat in a resistive load (sometimes referred to as the equivalent heating effect).

For a pure sine wave the equivalent RMS value is 0.707 times the peak value. Conversely the peak voltage can be calculated as 1.414 times the RMS Value. (if you remember 0.707 (Boeing 707) RMS from the peak voltage you can find the multiplier for RMS to peak by dividing .707 into 1 or $1 \div 0.707 = 1.414$)

Examples:

The peak voltage present in standard 120V RMS AC line voltage is $1.414 \times 120\text{V}$ or ~170 volts peak. The peak to peak (maximum negative to maximum positive peaks) would be two times the peak voltage or ~340 V Peak to Peak.

$$PP = 2 \times \text{Peak} \quad \text{or} \quad PP = 2 \times (\text{RMS} \times 1.414) \quad \text{or} \quad PP = 2 \times 169.7 \quad \text{or} \quad PP = 339.4 \text{ Volts}$$

An AC voltage that reads 65 volts on an RMS meter will have a peak to peak voltage of 184 Volts.

$$\text{Peak to peak Voltage} = 2 \times \text{RMS} \times 1.414 = 2 \times 65 \times 1.414 = 183.8 \text{ V PP}$$

If we start at the first positive peak to the next positive peak of one cycle of our sine wave you will observe that it crosses through zero twice in the cycle.

The time it takes for one cycle of a sine wave is the period of the waveform. A 100 Hz sine wave has a period of 0.01 seconds (or 10 milliseconds).

$$\text{period} = 1 \div \text{frequency} \quad \text{or} \quad \text{period} = 1 \div 100 \quad \text{or} \quad \text{period} = 0.010 \text{ seconds} \quad \text{or} \quad 10 \text{ milliseconds}$$

The average power dissipated by a 50 ohm resistor during one cycle of voltage with a peak voltage of 35 volts is 12.2 Watts.

$$P_{(avg)} = E^2_{(RMS)} \div R = (.707 \times 35)^2 \div 50 \text{ or } P = 612.3 \div 50 \text{ or } P = 12.25 \text{ watts}$$

IF a voltmeter reads 34 volts RMS when measuring a sinusoidal signal the peak voltage would be 48 Volts.

$$V_{(peak)} = V_{(RMS)} \times 1.414 \text{ or } V = 34 \times 1.414 \text{ or } P = 48.08 \text{ volts}$$

Transmitter Power

Because many amateur transmissions are not pure sine waves calculating average or RMS power is not easy. Measuring power for FM and CW (key down) power can be measured as average power. An example would be a two meter FM HT where power is specified as RMS power. SSB transmission on the other hand would be very difficult to measure in terms of RMS directly because the only time there is power present is when you are speaking into the microphone, and the power when you are speaking is a function of your voice level (a louder voice gives more transmit power). To characterize a SSB transmitter we talk about its output as PEP or peak envelope power. Where it gets confusing is that we talk about average power in the peak level of the transmitted power. If we were to look at our SSB signal we would be able to measure the peak level of our modulation as we speak into the microphone. Once we have the peak voltage we can apply the rules to find the RMS value of the peak voltage ($0.707 \times$ Peak voltage), which is called Peak Envelope Power or PEP (This assumes the audio modulation is a constant sine wave).

Peak Envelope Power (PEP) Calculations

When calculating Peak envelope power for a SSB transmitter using an oscilloscope to measure the voltage we use the equation above $Power = E^2 \div R$ Where Power in watts is equal to the RMS value of the RF Voltage divided by the transmitter/antenna impedance in ohms (usually 50 ohms). The oscilloscope measures the peak to peak voltage so to determine the peak voltage we divide it by 2. We multiply the peak voltage by .707 to get the RMS voltage that we will use in the equation.

G5B06

What is the output PEP from a transmitter if an oscilloscope measures 200 volts peak-to-peak across a 50 ohm dummy load connected to the transmitter output?

100 watts

$$PEP = ((200 \div 2) \times .707)^2 \div R \text{ or } PEP = [70.7]^2 \div 50 \text{ or } PEP = 4,998 \div 50 \text{ or } PEP = 99.97 \text{ watts}$$

G5B07

What value of an AC signal produces the same power dissipation in a resistor as a DC voltage of the same value?

The RMS value

G5B08

What is the peak-to-peak voltage of a sine wave that has an RMS voltage of 120 volts?

338.4 volts

$$Peak \ to \ Peak = 2 \ (1.414) \ (RMS) \ \text{or} \ PP = 2(1.414) \ (120) \ \text{or} \ 2(169.68) \ \text{or} \ PP = 339.36 \ \text{volts}$$

G5B09

What is the RMS voltage of a sine wave with a value of 17 volts peak?

12 volts

$$RMS = Peak \times 0.707 \ \text{or} \ RMS = 17 \times 0.707 \ \text{or} \ RMS = 12 \ \text{Volts}$$

G5B10

What percentage of power loss would result from a transmission line loss of 1 dB?

20.5 percent

See Table under question G5B01. It shows a 1 dB loss would be ~80% of the original power.

G5B11

What is the ratio of peak envelope power to average power for an unmodulated carrier?

1.00

With no modulation average and PEP are the same (such as CW or unmodulated AM)

G5B12

What would be the RMS voltage across a 50 ohm dummy load dissipating 1200 watts?

245 volts

To calculate the power refer to the ohms law triangle under question G5B03 to find the equation for Voltage (E) when power (P) and Resistance (R) are known.

$$E = \sqrt{P \times R} \quad \text{or} \quad E = \sqrt{1200 \times 50} \quad \text{or} \quad E = \sqrt{60,000} \quad \text{or} \quad E = 244.9 \text{ volts RMS}$$

G5B13

What is the output PEP of an unmodulated carrier if an average reading wattmeter connected to the transmitter output indicates 1060 watts?

1060 watts

Peak envelope power is equal to the average power if the carrier is not modulated as in a CW key down transmission or an AM transmission without any modulation

G5B14

What is the output PEP from a transmitter if an oscilloscope measures 500 volts peak-to-peak across a 50 ohm resistive load connected to the transmitter output?

625 watts

$$PEP = \left(\frac{500}{2} \times .707 \right)^2 \div R \quad \text{or} \quad PEP = (250 \times .707)^2 \div 50 \quad \text{or} \quad PEP = (176.75)^2 \div 50 \quad \text{or} \\ PEP = 31,240.56 \div 50 \quad \text{or} \quad PEP = 624.81 \text{ Watts}$$

G5C – Resistors, capacitors, and inductors in series and parallel; transformers

G5C01

What causes a voltage to appear across the secondary winding of a transformer when an AC voltage source is connected across its primary winding?

Mutual inductance

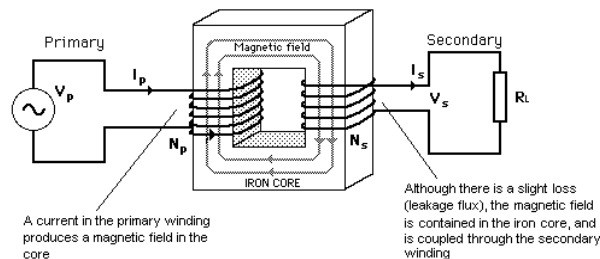

G5C02

What happens if you reverse the primary and secondary windings of a 4:1 voltage step down transformer?

The secondary voltage becomes 4 times the primary voltage

The ratio of the output turns to the input turns determines the output voltage to the input voltage ratio. A 100 turn primary with 100 volt AC input and a 25 turn secondary will give a 25 volt AC output. Reversing

the primary and secondary would have 100 volts ac on the 25 turn side and a 400 volt output on the 100 turn side.

G5C03

Which of the following components should be added to an existing resistor to increase the resistance?

A resistor in series

Remember resistors in series add $R_{(total)} = R_1 + R_2 + R_3 + \dots + R_n$

G5C04

What is the total resistance of three 100 ohm resistors in parallel?

33.3 ohms

The total value of equal value resistors in parallel is the resistance of the number of resistors in parallel divided into the value of one of the resistors.

$$R = 100 \div 3 \text{ or } R = 33.33\Omega$$

G5C05

If three equal value resistors in series produce 450 ohms, what is the value of each resistor?

150 ohms

$$R = R_{(sum)} \div \text{number of resistors} \text{ or } 450 \Omega \div 3 \text{ or } R = 150 \Omega$$

G5C06

What is the RMS voltage across a 500-turn secondary winding in a transformer if the 2250-turn primary is connected to 120 VAC?

26.7 volts

$$\text{Output voltage} = 120 V_{(rms)} (500 \div 2250) \text{ or output voltage} = 120 V_{(rms)} \div (.2222) \text{ or } 26.66 V_{(rms)}$$

G5C07

What is the turns ratio of a transformer used to match an audio amplifier having 600 ohm output impedance to a speaker having 4 ohm impedance?

12.2 to 1

Turns ratio is equal to the square root of the impedance ratio.

$$\text{Turns ratio} = \sqrt{(600 \Omega \div 4 \Omega)} \text{ or Turns Ratio} = \sqrt{150 \Omega} \text{ or Turns Ratio} = 12.25 \Omega$$

G5C08

What is the equivalent capacitance of two 5.0 nanofarad capacitors and one 750 picofarad capacitor connected in parallel?

10.750 nanofarads

$$5 \text{ nf} + 5 \text{ nf} + .750 \text{ nf} = 10.75 \text{ nanofarads}$$

Note: One nanofarad is equal to 1000 picofarads

G5C09

What is the capacitance of three 100 microfarad capacitors connected in series?

33.3 microfarads

$$\text{Total Capacity} = 100\mu \div 3 \text{ or } 33.3 \text{ microfarad's}$$

Series capacitors are like parallel resistors. In a circuit with the same value capacitors in series the total capacitance is equal to the number of capacitors in series divided into the value of one of the capacitors..

G5C10

What is the inductance of three 10 millihenry inductors connected in parallel?

3.3 millihenrys

$$\text{Total inductance} = 10 \text{ millihenry} \div 3 \text{ or Total inductance} = 3.33 \text{ millihenry}$$

Parallel Inductors are like parallel resistors. In a circuit with the same value inductors in parallel the total inductance is equal to the number of inductors in parallel divided into the value of one of the inductors.

G5C11

What is the inductance of a 20 millihenry inductor connected in series with a 50 millihenry inductor?

70 millihenrys

Total inductance = 20 millihenry + 50 millihenry or 70 millihenry

Total inductance of series inductors is simply the sum of all the inductors in series.

G5C12

What is the capacitance of a 20 microfarad capacitor connected in series with a 50 microfarad capacitor?

14.3 microfarads

The total value for parallel capacitors is $1 \div ((1 \div C_1) + (1 \div C_2))$ or Total Value $1 \div ((1 \div 20) + (1 \div 50))$ or

Total Value = $1 \div ((0.05) + (0.02))$ or Total value = $1 \div 0.07$ or Total Value = 14.285

G5C13

Which of the following components should be added to a capacitor to increase the capacitance?

A capacitor in parallel

Capacitors in parallel simply add $C_1 + C_2 + C_3 + \dots + C_n$

G5C14

Which of the following components should be added to an inductor to increase the inductance?

An inductor in series

Inductors in Series simply add $L_1 + L_2 + L_3 + \dots + L_n$

G5C15

What is the total resistance of a 10 ohm, a 20 ohm, and a 50 ohm resistor connected in parallel?

5.9 ohms

The total value for parallel Resistors is $1 \div ((1 \div R_1) + (1 \div R_2) + (1 \div R_3))$ or Total Value $1 \div ((1 \div 10) + (1 \div 20) + (1 \div 50))$ or = $1 \div (.1) + (.05) + (.02)$ or = $1 \div .17$ or Total Value = 5.882 ohms

note: The total resistance in a parallel resistor circuit is always less than the lowest value resistor in the parallel circuit.

G5C16

Why is the conductor of the primary winding of many voltage **step up** transformers larger in diameter than the conductor of the secondary winding?

To accommodate the higher current of the primary

Assuming no magnetic loss the current in the primary winding will be equal to the turn's ratio of the transformer. Therefore a secondary current will be half as high as the primary current if the output voltage is twice the input voltage.

G5C17

What is the value in nanofarads (nF) of a 22,000 pF capacitor?

22 nF

One nanofarad is equal to 1000 picofarads.

G5C18

What is the value in microfarads of a 4700 nanofarad (nF) capacitor?

4.7 μ F

one microfarad is equal to 1000 nanofarads or 1,000,000 picofarads.

SUBELEMENT G6 – CIRCUIT COMPONENTS

[2 Exam Questions – 2 Groups]

G6A – Resistors; Capacitors; Inductors; Rectifiers; solid state diodes and transistors; vacuum tubes; batteries

G6A01

What is the minimum allowable discharge voltage for maximum life of a standard 12 volt lead acid battery?

10.5 volts

Letting a battery discharge to below 10.5 volts will shorten its lifetime and deep discharge may permanently damage it.

G6A02

What is an advantage of the low internal resistance of nickel-cadmium batteries?

High discharge current

G6A03

What is the approximate junction threshold voltage of a germanium diode?

0.3 volts

See Graphic in G6A05

G6A04

When is it acceptable to recharge a carbon-zinc primary cell?

Never

Charging carbon-zinc and alkaline cells may cause them to explode.

G6A05

What is the approximate junction threshold voltage of a conventional silicon diode?

0.7 volts

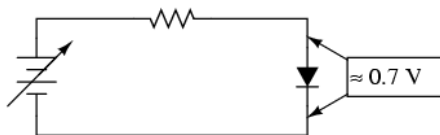

The voltage drop for a germanium diode is 0.3 volts

G6A06

Which of the following is an advantage of using a Schottky diode in an RF switching circuit rather than a standard silicon diode?

Lower capacitance

G6A07

What are the stable operating points for a bipolar transistor used as a switch in a logic circuit?

Its saturation and cutoff regions

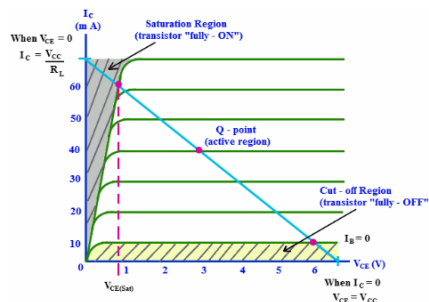
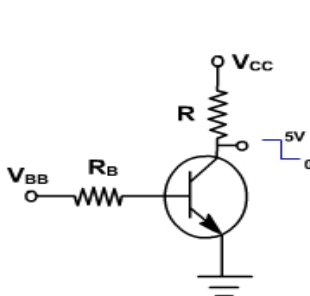

G6A08

Why must the cases of some large power transistors be insulated from ground?

To avoid shorting the collector or drain voltage to ground

Many times they are electrically and thermally connected to the case for heat dissipation

G6A09

Which of the following describes the construction of a MOSFET?

The gate is separated from the channel with a thin insulating layer

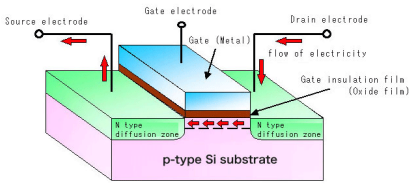

Construction of MOSFET

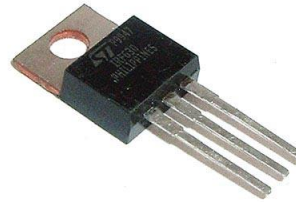

G6A10

Which element of a triode vacuum tube is used to regulate the flow of electrons between cathode and plate?

Control grid



G6A11

Which of the following solid state devices is most like a vacuum tube in its general operating characteristics?

A field effect transistor

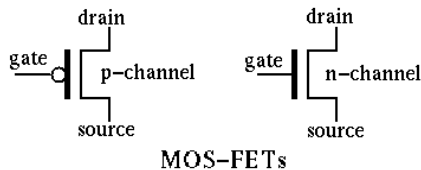

In the field Effect Transistor (FET) current flow between the Drain and Source is controlled by a Gate voltage not a current, much like the control grid in the vacuum tube the current flow is controlled by a bias voltage not a current. This is different than a bipolar transistor where collector the emitter current is controlled by a smaller base current.

G6A12

What is the primary purpose of a screen grid in a vacuum tube?

To reduce grid-to-plate capacitance

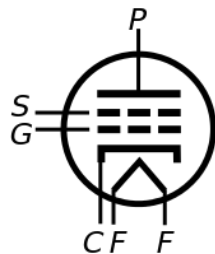

G6A13

Why is the polarity of applied voltages important for polarized capacitors?

- A. Incorrect polarity can cause the capacitor to short-circuit
- B. Reverse voltages can destroy the dielectric layer of an electrolytic capacitor
- C. The capacitor could overheat and explode
- D. All of these choices are correct

G6A14

Which of the following is an advantage of ceramic capacitors as compared to other types of capacitors?

Comparatively low cost



G6A15

Which of the following is an advantage of an electrolytic capacitor?

High capacitance for a given volume

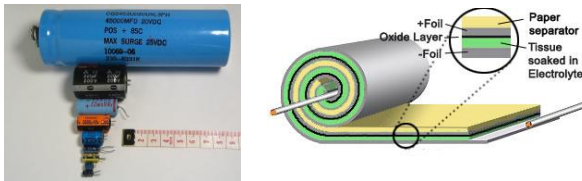

G6A16

What will happen to the resistance if the temperature of a resistor is increased?

It will change depending on the resistor's temperature coefficient

Most resistors exhibit a positive temperature gradient (coefficient), which means their resistance increases with temperature. There are some that have a negative temperature gradient (coefficient) where their resistance decreases with temperature.

G6A17

Which of the following is a reason not to use wire-wound resistors in an RF circuit?

The resistor's inductance could make circuit performance unpredictable



G6A18

What is an advantage of using a ferrite core toroidal inductor?

- A. Large values of inductance may be obtained
- B. The magnetic properties of the core may be optimized for a specific range of frequencies
- C. Most of the magnetic field is contained in the core
- D. All of these choices are correct



G6A19

How should the winding axes of two solenoid inductors be oriented to minimize their mutual inductance?

At right angles to each other

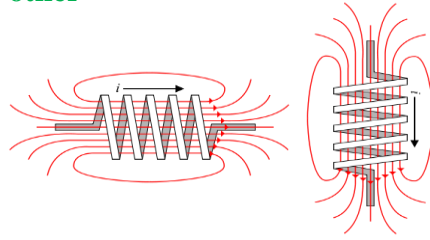

G6B - Analog and digital integrated circuits (ICs); microprocessors; memory; I/O devices; microwave ICs (MMICs); display devices

G6B01

Which of the following is an analog integrated circuit?

Linear voltage regulator

In electronics, a linear regulator is a system used to maintain a steady voltage. The resistance of the regulator varies in accordance with the load resulting in a constant output voltage. The regulating device is made to act like a variable resistor, continuously adjusting a voltage divider network to maintain a constant output voltage, and continually dissipating the difference between the input and regulated voltages as wasted heat.

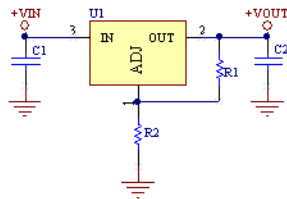

G6B02

What is meant by the term MMIC?

Monolithic Microwave Integrated Circuit

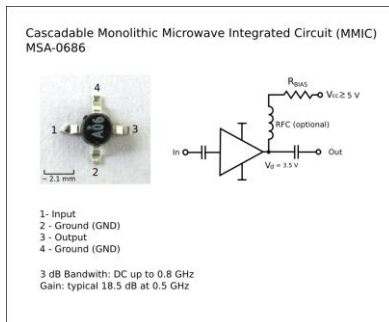

G6B03

Which of the following is an advantage of CMOS integrated circuits compared to TTL integrated circuits?

Low power consumption

This is because unlike a bi-polar transistor control of current or switching does not require a current flow (which generates heat). Control is by a bias voltage not a current.

G6B04

What is meant by the term ROM?

Read Only Memory

This is a type of memory chip that does not lose information even if the power is turned off. Once data is programmed into the ROM chip, its contents cannot be altered.

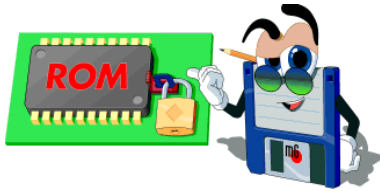

G6B05

What is meant when memory is characterized as non-volatile?

The stored information is maintained even if power is removed

See the answer above in G6B04

G6B06

What kind of device is an integrated circuit operational amplifier?

Analog

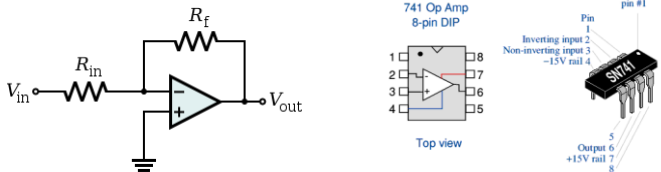

See operational amplifier tutorial on page 94.

G6B07 (D)

Which of the following is an advantage of an LED indicator compared to an incandescent indicator?

- A. Lower power consumption
- B. Faster response time
- C. Longer life
- D. All of these choices are correct**

G6B08

How is an LED biased when emitting light?

Forward Biased

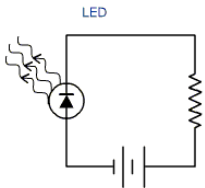

G6B09

Which of the following is a characteristic of a liquid crystal display?

It requires ambient or back lighting



G6B10

What two devices in an Amateur Radio station might be connected using a USB interface?

Computer and transceiver

G6B11

What is a microprocessor?

A computer on a single integrated circuit



G6B12

Which of the following connectors would be a good choice for a serial data port?

DE-9 (also called a DB9 Connector)



G6B13

Which of these connector types is commonly used for RF connections at frequencies up to 150 MHz?

PL-259



G6B14

Which of these connector types is commonly used for audio signals in Amateur Radio stations?

RCA Phono



G6B15

What is the main reason to use keyed connectors instead of non-keyed types?

Reduced chance of incorrect mating

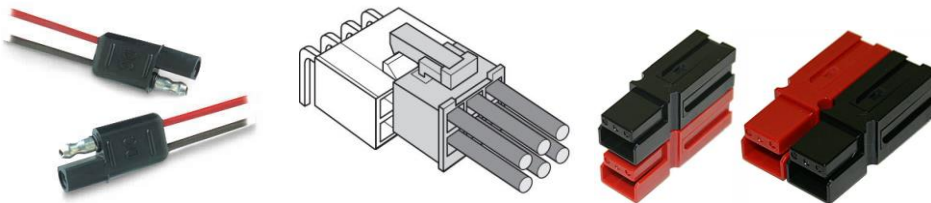

G6B16

Which of the following describes a type N connector?

A moisture-resistant RF connector useful to 10 GHz



G6B17

What is the general description of a DIN type connector?

A family of multiple circuit connectors suitable for audio and control signals



These connectors are typically used for Microphone and data connections on base and mobile radios

G6B18

What is a type SMA connector?

A small threaded connector suitable for signals up to several GHz (actually useable to >20 GHz)



G7 – PRACTICAL CIRCUITS [3 Exam Questions – 3 Groups]

G7A Power supplies; and schematic symbols

G7A01

What useful feature does a power supply bleeder resistor provide?

It ensures that the filter capacitors are discharged when power is removed

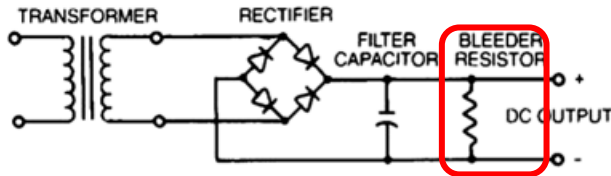

G7A02

Which of the following components are used in a power supply filter network?

Capacitors and inductors

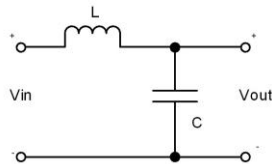

G7A03

What is the peak-inverse-voltage across the rectifiers in a full-wave bridge power supply?

Equal to the normal peak output voltage of the power supply

G7A04

What is the peak-inverse-voltage across the rectifier in a half-wave power supply?

Two times the normal peak output voltage of the power supply

G7A05

What portion of the AC cycle is converted to DC by a half-wave rectifier?

180 degrees

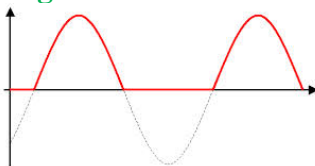

G7A06

What portion of the AC cycle is converted to DC by a full-wave rectifier?

360 degrees

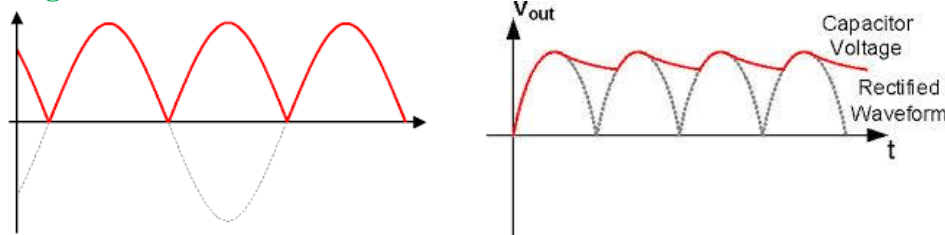

G7A07

What is the output waveform of an unfiltered full-wave rectifier connected to a resistive load?

A series of DC pulses at twice the frequency of the AC input

See the first illustration in G7A06 above.

G7A08

Which of the following is an advantage of a switchmode power supply as compared to a linear power supply?

High frequency operation allows the use of smaller components

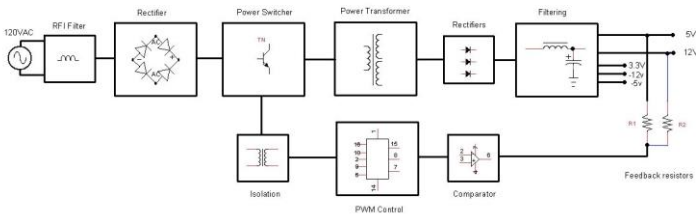

In a switching power supply the raw 60 Hz line voltage is rectified and then the resulting DC is switched into a square wave at typically a 20 kHz rate. This higher frequency AC is passed through transformers that are much smaller and lighter since they do not need to pass the lower 60 Hz and the final rectified 20 kHz does not require the larger capacitors that would be needed for a linear power supply that is filtering 60 or 120 Hz (a full wave rectifier output is 120 Hz). See the waveform in G7A06

G7A09 (C)

Which symbol in figure G7-1 represents a field effect transistor?

Symbol 1

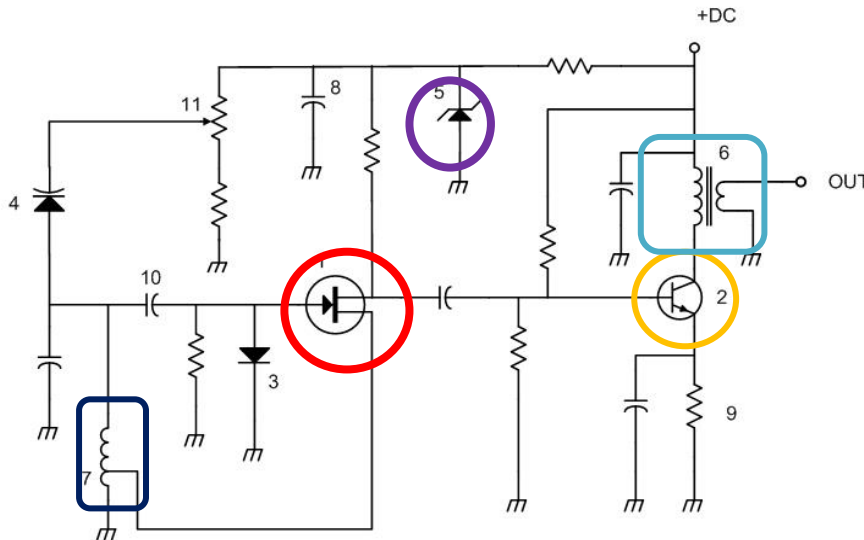

Figure G7-1

G7A10 (D)

Which symbol in figure G7-1 represents a Zener diode?

Symbol 5

G7A11 (B)

Which symbol in figure G7-1 represents an NPN junction transistor?

Symbol 2

G7A12 (C)

Which symbol in Figure G7-1 represents a multiple-winding transformer?

Symbol 6

G7A13 (A)

Which symbol in Figure G7-1 represents a tapped inductor?

Symbol 7

G7B - Digital circuits; amplifiers and oscillators

G7B01

Complex digital circuitry can often be replaced by what type of integrated circuit?

Microcontroller (or Microprocessor)

G7B02

Which of the following is an advantage of using the binary system when processing digital signals?

Binary "one's" and "zero's" are easy to represent by an "on" or "off" state

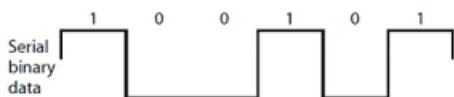

G7B03

Which of the following describes the function of a two input AND gate?

Output is high only when both inputs are high

See Appendix of reference materials page 99.



G7B04

Which of the following describes the function of a two input NOR gate?

Output is low when either or both inputs are high

See Appendix of reference materials page 99.



G7B05

How many states does a 3-bit binary counter have?

8

Count	Bit 3	Bit 2	Bit 1
0	0	0	0
1	0	0	1
2	0	1	0
3	0	1	1
4	1	0	0
5	1	0	1
6	1	1	0
7	1	1	1

G7B06

What is a shift register?

A clocked array of circuits that passes data in steps along the array

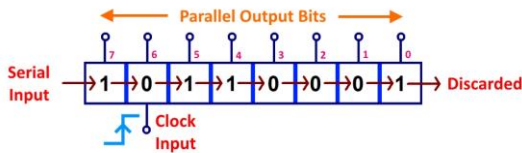

G7B07

What are the basic components of virtually all sine wave oscillators?

A filter and an amplifier operating in a feedback loop

Any amplifier that operates with positive (in phase) feedback will oscillate. Remember the squeal from a public address system when the microphone gets too close to the speaker? That is an oscillator.

G7B08

How is the efficiency of an RF power amplifier determined?

Divide the RF output power by the DC input power

Example: A 100 watt 2 meter power amplifier that draws 10 amperes from a 13.8 Volt Power supply has an efficiency of 72%.

$$\text{Efficiency} = P_{out} \div P_{in} = 100 \text{ watts} \div (13.8 \times 10) = 100 \div 138 \text{ or } 0.72 \text{ or Efficiency} = 72\%$$

G7B09

What determines the frequency of an LC oscillator?

The inductance and capacitance in the tank circuit

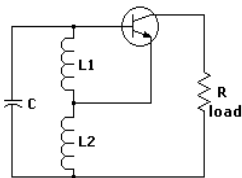

Figure 1 - schematic of a hartley oscillator

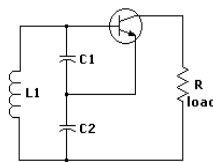
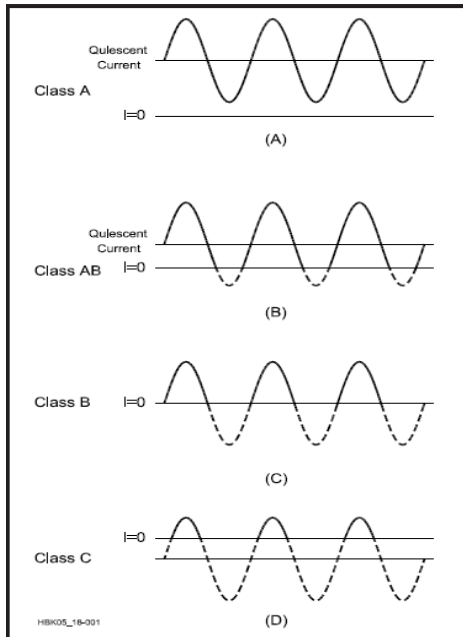

Figure 2 - schematic of a collpitts oscillator

Amplifier Class Operation Tutorial

Amplifiers are categorized by their type or class of operation, and circuit configuration.

CLASSES OF OPERATION (A, AB, B & C)



The class of operation of an amplifier stage is defined by its conduction angle, the angular portion of the sine wave drive cycle, in degrees, during which plate current (or collector or drain current in the case of transistors) flows. This, in turn, determines the amplifier's efficiency and linearity.

Class A: The conduction angle is 360° . DC bias and drive level are set so that the device is not driven to output current cutoff at any point in the driving-voltage cycle, so some device output current flows throughout the complete 360° of the cycle. Output voltage is generated by the variation of output current flowing through the load resistance. Maximum linearity and gain are achieved in a Class A amplifier, but the efficiency of the stage is low. Maximum theoretical efficiency is 50%, but 25 to 30% is more common in practice.

Class AB: The conduction angle is greater than 180° but less than 360° . In other words, dc bias and drive level are adjusted so device output current flows during appreciably more than half the drive cycle, but less than the whole drive cycle. Efficiency is much better than Class A, typically reaching 50-60% at peak output power. Class AB linearity and gain are not as good as that achieved in Class A, but are very acceptable for even the most rigorous high-power SSB applications in Amateur Radio.

Class B: Conduction angle = 180° . Bias and RF drive are set so that the device is just cut off with no signal applied (see Fig 18.1C), and device output current flows during one half of the drive cycle. Efficiency commonly reaches as high as 65%, with fully acceptable linearity.

Class C: The conduction angle is much less than 180° —typically 90° . DC bias is adjusted so that the device is cut off when no drive signal is applied. Output current flows only during positive crests in the drive cycle, so it consists of pulses at the drive frequency. Efficiency is relatively high—up to 80%—but linearity is extremely poor. Thus Class C amplifiers are not suitable for amplification of amplitude modulated signals such as SSB or AM, but are quite satisfactory for use in on off keyed stages or with frequency or phase modulation. Gain is lower than for the previous classes of operation, typically 10-13 dB.

G7B10

Which of the following is a characteristic of a Class A amplifier?

Low distortion

This is because 100 % of the waveform is amplified

G7B11

For which of the following modes is a Class C power stage appropriate for amplifying a modulated signal?

CW

G7B12

Which of these classes of amplifiers has the highest efficiency?

Class C

G7B13

What is the reason for neutralizing the final amplifier stage of a transmitter?

To eliminate self-oscillations

G7B14

Which of the following describes a linear amplifier?

An amplifier in which the output preserves the input waveform

G7C - Receivers and transmitters; filters, oscillators

G7C01

Which of the following is used to process signals from the balanced modulator then send them to the mixer in some single sideband phone transmitters?

Filter

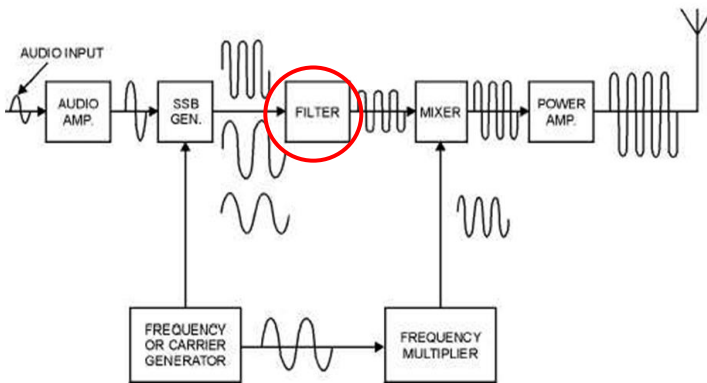

G7C02

Which circuit is used to combine signals from the carrier oscillator and speech amplifier then send the result to the filter in some single sideband phone transmitters?

Balanced modulator

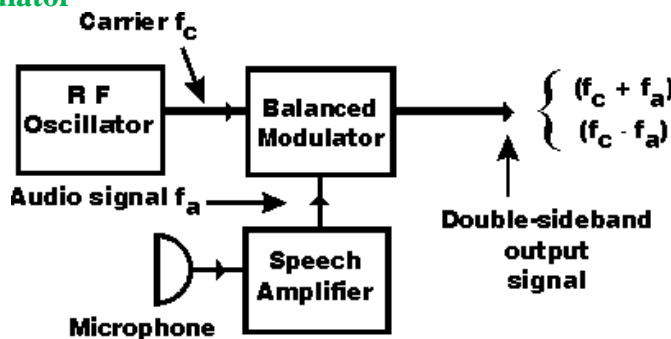

G7C03

What circuit is used to process signals from the RF amplifier and local oscillator, then send the result to the IF filter in a superheterodyne receiver?

Mixer

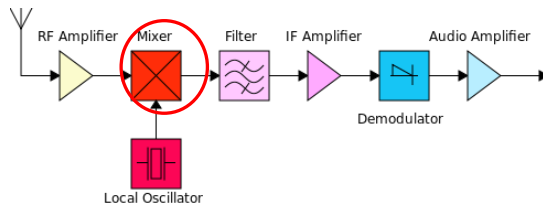

G7C04

What circuit is used to combine signals from the IF amplifier and BFO and send the result to the AF amplifier in some single sideband receivers?

Product detector

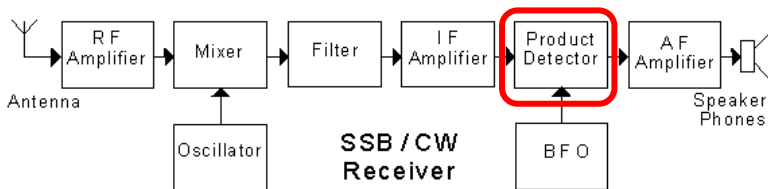

G7C05

Which of the following is an advantage of a transceiver controlled by a direct digital synthesizer (DDS)?

Variable frequency with the stability of a crystal oscillator

G7C06

What should be the impedance of a low-pass filter as compared to the impedance of the transmission line into which it is inserted?

About the same

G7C07

What is the simplest combination of stages that implement a superheterodyne receiver?

HF oscillator, mixer, detector

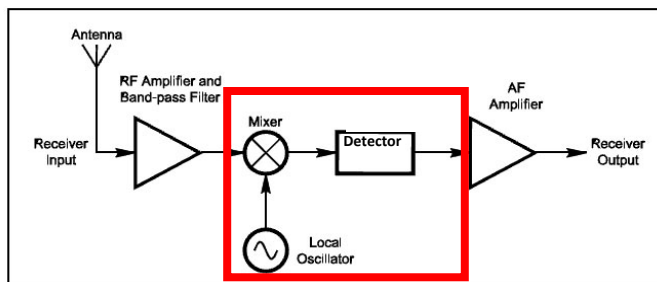

G7C08

What type of circuit is used in many FM receivers to convert signals coming from the IF amplifier to audio?

Discriminator

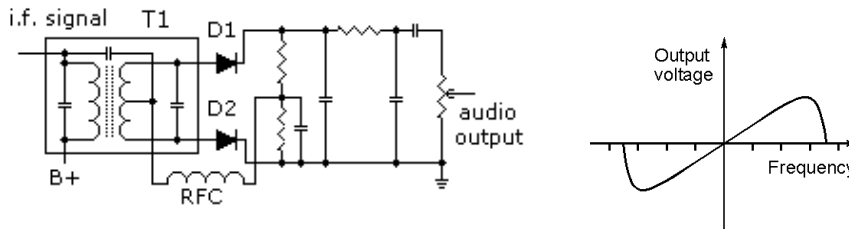

G7C09

Which of the following is needed for a Digital Signal Processor IF filter?

- A. An analog to digital converter**
- B. A digital to analog converter**
- C. A digital processor chip**
- D. All of the these choices are correct**

G7C10

How is Digital Signal Processor filtering accomplished?

By converting the signal from analog to digital and using digital processing

G7C11

What is meant by the term "software defined radio" (SDR)?

A radio in which most major signal processing functions are performed by software

SUBELEMENT G8 – SIGNALS AND EMISSIONS

[3 Exam Questions – 3 Groups]

G8A - Carriers and modulation: AM; FM; single sideband; modulation envelope; digital modulation; over modulation

G8A01

How is an FSK signal generated?

By changing an oscillator's frequency directly with a digital control signal

G8A02

What is the name of the process that changes the phase angle of an RF wave to convey information?

Phase modulation

G8A03

What is the name of the process that changes the instantaneous frequency of an RF wave to convey information?

Frequency modulation

G8A04

What emission is produced by a reactance modulator connected to a transmitter RF amplifier stage?

Phase modulation

G8A05 (D)

What type of modulation varies the instantaneous power level of the RF signal?

Amplitude modulation

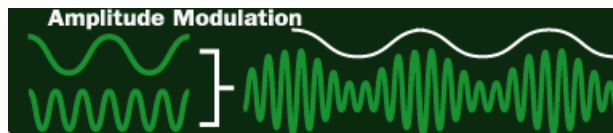

G8A06

What is one advantage of carrier suppression in a single sideband phone transmission versus full carrier amplitude modulation?

Available transmitter power can be used more effectively

Lower Sideband Upper Sideband

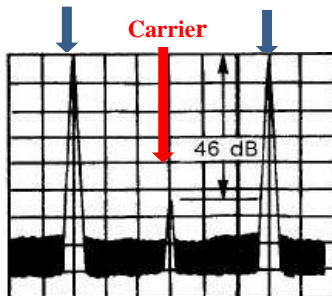

This graphic shows a double sideband AM signal with a suppressed carrier

In a single sideband transmitter the carrier is suppressed and only one of the sidebands is transmitted. The carrier is not needed to convey the information and the two remaining sidebands contain identical information so we do not need to transmit both of them.

G8A07

Which of the following phone emissions uses the narrowest bandwidth?

Single sideband

G8A08

Which of the following is an effect of over modulation?

Excessive bandwidth

G8A09

What control is typically adjusted for proper ALC setting on an amateur single sideband transceiver?

Transmit audio or microphone gain

G8A10

What is meant by the term flat-topping when referred to a single sideband phone transmission?

Signal distortion caused by excessive drive

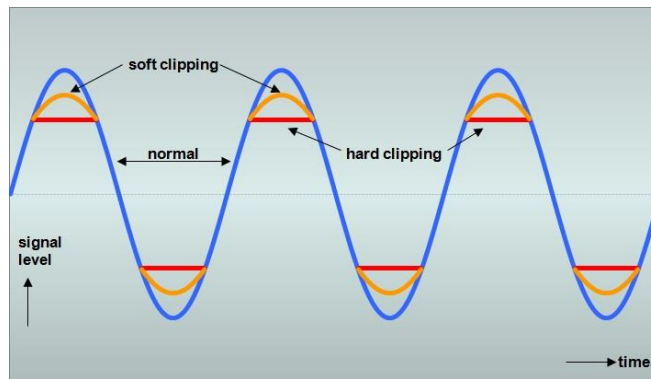

G8A11

What is the modulation envelope of an AM signal?

The waveform created by connecting the peak values of the modulated signal

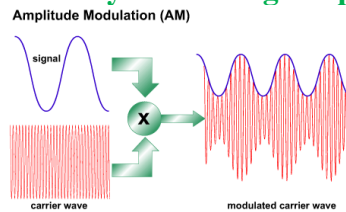

G8B - Frequency mixing; multiplication; bandwidths of various modes; deviation; duty cycle

G8B01

What receiver stage combines a 14.250 MHz input signal with a 13.795 MHz oscillator signal to produce a 455 kHz intermediate frequency (IF) signal?

Mixer

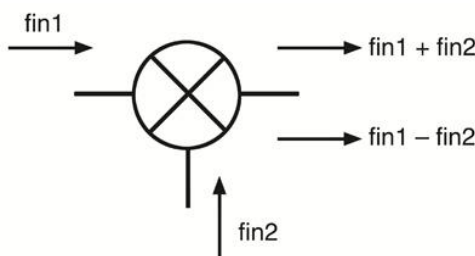

<u>Input</u>	
$f_{in\ 1} = 14.240\ \text{MHz}$	$f_{in\ 2} = 13.975\ \text{MHz}$
<u>Output</u>	
$f_{in\ 1} + f_{in\ 2} (\text{Sum}) = 14.240\ \text{MHz} + 13.975\ \text{MHz} = 28.215\ \text{MHz}$	
$f_{in\ 1} - f_{in\ 2} (\text{Difference}) = 14.240\ \text{MHz} - 13.975\ \text{MHz} = 0.455\ \text{MHz}$	

G8B02

If a receiver mixes a 13.800 MHz VFO with a 14.255 MHz received signal to produce a 455 kHz intermediate frequency (IF) signal, what type of interference will a 13.345 MHz signal produce in the receiver?

Image response

Both of these inputs would produce a signal at the 455 KHz IF Frequency. A receiver with poor image rejection would receive both of these frequencies.

The difference frequency between a 14.255 MHz input and a 13.800 MHz Local oscillator would be:

$$14.255 \text{ MHz} - 13.800 \text{ MHz} \text{ or } 0.455 \text{ MHz}$$

The difference frequency between a 13.345 MHz input and a 13.800 MHz Local oscillator would be:

$$13.800 \text{ MHz} - 13.345 \text{ MHz} \text{ or } 0.455 \text{ MHz}$$

G8B03

What is another term for the mixing of two RF signals?

Heterodyning

G8B04

What is the stage in a VHF FM transmitter that generates a harmonic of a lower frequency signal to reach the desired operating frequency?

Multiplier

Multipliers are special class C amplifiers that are biased at 3 to 10 times the normal cutoff bias. They are used to generate a frequency that has multiple harmonics of the lower frequency input. The figure below illustrates a simple frequency multiplier. The input is 14 megahertz and the output is 140 megahertz, or ten times the input frequency. The tuned circuit is tuned to the 10th the harmonic, or 140 MHz.

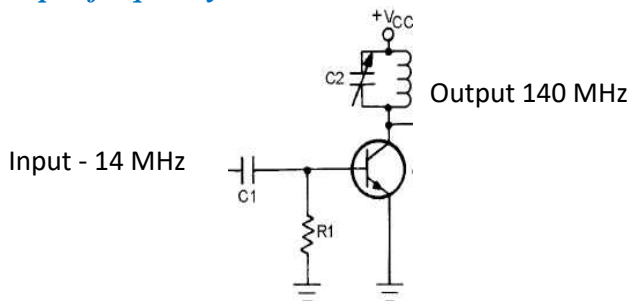

G8B05

What is the approximate bandwidth of a PACTOR3 or WINMOR signal at maximum data rate?

2300 Hz

G8B06

What is the total bandwidth of an FM phone transmission having 5 kHz deviation and 3 kHz modulating frequency?

16 kHz

The bandwidth is the max deviation, which is plus or minus 5 KHz plus the maximum modulating frequency which is 3 KHz for a total deviation of plus and minus 8 KHz for a total occupied bandwidth of 16 KHz.

$$\text{Total bandwidth} = 2 \times (f_m (\text{modulation}) + f (\text{deviation})) \text{ or } 2 (3 \text{ kHz} + 5 \text{ kHz}) \text{ or } 2 (8 \text{ kHz}) \text{ or } 16 \text{ kHz}$$

G8B07

What is the frequency deviation for a 12.21 MHz reactance modulated oscillator in a 5 kHz deviation, 146.52 MHz FM phone transmitter?

416.7 Hz

12.21 MHz must be multiplied by 12 (146.52/12.21) to achieve a 146.52 MHz signal. Since the deviation on the 12.21 signal is also multiplied the actual deviation at 12.21 MHz would be 1/12 of the desired modulation or 5 KHz ÷ 12 or 416.66 Hz.

G8B08

Why is it important to know the duty cycle of the mode you are using when transmitting?

Some modes have high duty cycles which could exceed the transmitter's average power rating.
For instance a 100 watt SSB HF rig will not do 100 watts of key down CW or high duty cycle Digital without exceeding the output average power rating, causing it to overheat.

G8B09

Why is it good to match receiver bandwidth to the bandwidth of the operating mode?

It results in the best signal to noise ratio
Excessive bandwidth beyond what is needed just raises the noise floor of the received signal and possibly receives other strong nearby signals.

G8B10

What is the relationship between transmitted symbol rate and bandwidth?

Higher symbol rates require wider bandwidth

G8C – Digital emission modes

G8C01

Which of the following digital modes is designed to operate at extremely low signal strength on the HF bands?

JT9 and JT65

JT65 is intended for extremely weak but slowly varying signals, such as those found on troposcatter or Earth-Moon-Earth (EME) communication. JT65 can decode signals many decibels below the noise floor, and can often allow amateurs to successfully exchange contact information without signals being audible to the human ear.

JT9, a new mode designed especially for the LF, MF, and HF bands, in addition to the popular mode JT65. Both modes were designed for making reliable, confirmed QSOs under extreme weak-signal conditions. They use nearly identical message structure and source encoding. JT65 was designed for EME (“moonbounce”) on the VHF/UHF bands and has also proved very effective for worldwide QRP communication at HF. In contrast, JT9 is optimized for HF and lower frequencies. JT9 is about 2 dB more sensitive than JT65A while using less than 10% of the bandwidth. With either mode, world-wide QSOs are possible with power levels of a few watts and compromise antennas. A 2 kHz slice of spectrum is essentially full when occupied by ten JT65 signals. As many as 100 JT9 signals can fit into the same space, without overlap.

G8C02

How many data bits are sent in a single PSK31 character?

The number varies

Just like Morse code the characters have longer or shorter number of bits based on the frequency of usage. An E would have fewer bits than a Z.

G8C03

What part of a data packet contains the routing and handling information?

Header

G8C04

Which of the following describes Baudot code?

A 5-bit code with additional start and stop bits

The Baudot code, invented by Émile Baudot, is a character set predating EBCDIC and ASCII. It was the predecessor to the International Telegraph Tele-printer code in use until the advent of ASCII.

G8C05

In the PACTOR protocol, what is meant by an NAK response to a transmitted packet?

The receiver is requesting the packet be retransmitted

G8C06

What action results from a failure to exchange information due to excessive transmission attempts when using PACTOR or WINMOR?

The connection is dropped

G8C07

How does the receiving station respond to an ARQ data mode packet containing errors?

It requests the packet be retransmitted

G8C08

Which of the following statements is true about PSK31?

Upper case letters use longer Varicode signals and thus slow down transmission

G8C09

What does the number 31 represent in "PSK31"?

The approximate transmitted symbol rate

G8C10

How does forward error correction (FEC) allow the receiver to correct errors in received data packets?

By transmitting redundant information with the data

G8C11

How are the two separate frequencies of a Frequency Shift Keyed (FSK) signal identified?

Mark and Space

G8C12

Which type of code is used for sending characters in a PSK31 signal?

Varicode

SUBELEMENT G9 – ANTENNAS AND FEED LINES **[4 Exam Questions – 4 Groups]**

G9A - Antenna feed lines: characteristic impedance, and attenuation; SWR calculation, measurement and effects; matching networks

G9A01

Which of the following factors determine the characteristic impedance of a parallel conductor antenna feed line?

The distance between the centers of the conductors and the radius of the conductors

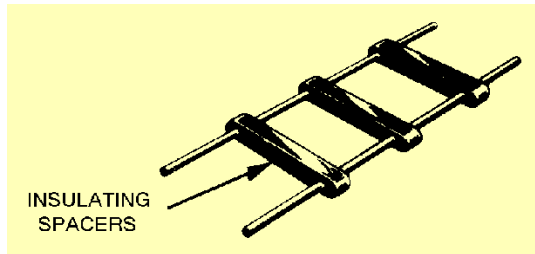
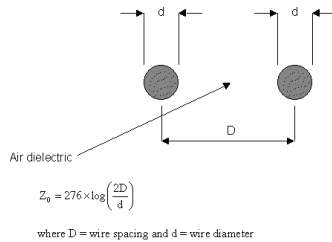

G9A02

What are the typical characteristic impedances of coaxial cables used for antenna feed lines at amateur stations?

50 and 75 ohms

G9A03

What is the characteristic impedance of flat ribbon TV type twinlead?

300 ohms

G9A04

What might cause reflected power at the point where a feed line connects to an antenna?

A difference between feed line impedance and antenna feed point impedance

G9A05

How does the attenuation of coaxial cable change as the frequency of the signal it is carrying increases?

Attenuation increases

G9A06

In what units is RF feed line loss usually expressed?

Decibels per 100 feet

Usually manufacturer specified at a specific frequency (s).

G9A07

What must be done to prevent standing waves on an antenna feed line?

The antenna feed point impedance must be matched to the characteristic impedance of the feed line

G9A08

If the SWR on an antenna feed line is 5 to 1, and a matching network at the transmitter end of the feed line is adjusted to 1 to 1 SWR, what is the resulting SWR on the feed line?

5 to 1

The matching network allows the transmitter to see a matched load; it does not change the characteristic impedance of the feedline or antenna it is matching to.

G9A09

What standing wave ratio will result when connecting a 50 ohm feed line to a non-reactive load having 200 ohm impedance?

4:1

SWR = 200 ÷ 50 or 4:1 SWR (RL is the load impedance, RO is the transmitter output impedance)

G9A10

What standing wave ratio will result when connecting a 50 ohm feed line to a non-reactive load having 10 ohm impedance?

5:1

SWR = 50 ÷ 10 or 5:1 VSWR

G9A11

What standing wave ratio will result when connecting a 50 ohm feed line to a non-reactive load having 50 ohm impedance?

1:1

SWR = 50 ÷ 50 or 1:1 VSWR

G9A12

What standing wave ratio will result when connecting a 50 ohm feed line to a non-reactive load having 25 ohm impedance?

2:1

SWR = 50 ÷ 25 or 2:1 VSWR

G9A13

What standing wave ratio will result when connecting a 50 ohm feed line to an antenna that has a purely resistive 300 ohm feed point impedance?

6:1

SWR = 300 ÷ 50 or 6:1 VSWR

G9A14

What is the interaction between high standing wave ratio (SWR) and transmission line loss?

If a transmission line is lossy, high SWR will increase the loss

G9A15

What is the effect of transmission line loss on SWR measured at the input to the line?

The higher the transmission line loss, the more the SWR will read artificially low

One way to express SWR is Return Loss. This is the amount of the signal returned from the load (antenna and feed line) relative to the power applied (referred to as incident or forward power). In a perfect system no signal is returned back to the transmitter. A short or open circuit will return 100 % of the signal back to the transmitter (0 dB return loss).

Return Loss in dB = 10 (log) (Reflected Power ÷ Incident power)

An open or short with coax feeding it that has 4 dB of loss this would mean there is a 4 dB of loss from the transmitter to the open or short circuit and 4 dB more of loss or the returned (reflected) signal to the back to the transmitter for a total of 8 dB. Therefore an open or shorted antenna would show 8dB return loss which is the equivalent of an SWR of 2.3. Because of the influence of line loss for an accurate measurement of an antenna it should be measured with low loss transmission line as close to the antenna as possible. See page 100 for a table converting return loss to SWR

G9B - Basic antennas

G9B01

What is one disadvantage of a directly fed random-wire HF antenna?

You may experience RF burns when touching metal objects in your station

G9B02

Which of the following is a common way to adjust the feed point impedance of a quarter wave ground plane vertical antenna to be approximately 50 ohms?

Slope the radials downward

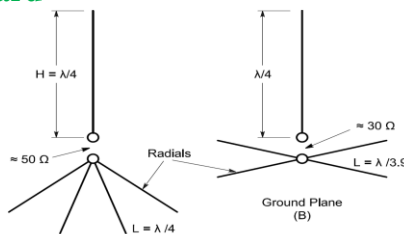

G9B03

What happens to the feed point impedance of a ground plane antenna when its radials are changed from horizontal to sloping downward?

It increases

It goes from 30 ohms to 50 ohms.

G9B04

What is the radiation pattern of a dipole antenna in free space in the plane of the conductor?

It is a figure-eight at right angles to the antenna

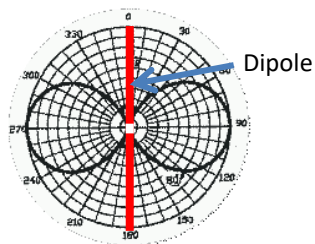

G9B05

How does antenna height affect the horizontal (azimuthal) radiation pattern of a horizontal dipole HF antenna?

If the antenna is less than 1/2 wavelength high, the azimuthal pattern is almost omnidirectional

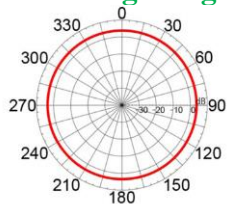

G9B06

Where should the radial wires of a ground-mounted vertical antenna system be placed?

On the surface of the Earth or buried a few inches below the ground



G9B07

How does the feed point impedance of a 1/2 wave dipole antenna change as the antenna is lowered below 1/4 wave above ground?

It steadily decreases

G9B08

How does the feed point impedance of a 1/2 wave dipole change as the feed point is moved from the center toward the ends?

It steadily increases

A dipole is basically a single-band antenna. It is sometimes used on its 3rd harmonic (i.e., a 40m dipole may also be used on 15m), but if it is fed with coax, it should not be used on its even harmonic frequencies.

That's because the impedance of the dipole on its even harmonics is too high (typically >2K Ohms) and feedline losses are excessively high.

By moving the feed point away from the center of the dipole, we enable the antenna to be used on more harmonic frequencies and we transform the mono-band antenna into a good multi-band antenna. Because of the rise in input impedance you will need to use a 4:1 or 6:1 balun.

G9B09

Which of the following is an advantage of a horizontally polarized as compared to a vertically polarized HF antenna?

Lower ground reflection losses

G9B10

What is the approximate length for a 1/2 wave dipole antenna cut for 14.250 MHz?

32 feet

A half wave dipole in feet is equal to $468 \div \text{frequency in MHz}$, therefore for 14.250 MHz the length would be $468 \div 14.250$ or 32.8 feet.

G9B11

What is the approximate length for a 1/2 wave dipole antenna cut for 3.550 MHz?

131 feet

A half wave dipole in feet is equal to $468 \div \text{frequency in MHz}$, therefore for 3.550 MHz the length would be $468 \div 3.550$ or 131.8 feet.

G9B12

What is the approximate length for a 1/4 wave vertical antenna cut for 28.5 MHz?

8 feet

A half wave antenna in feet is equal to $468 \div \text{frequency in MHz}$, therefore for 28.5 MHz the length would be $468 \div 28.5$ or 16.4 feet. The question asks for a $\frac{1}{4}$ wavelength antenna so it would be $\frac{1}{2}$ of the $\frac{1}{2}$ wavelength antenna or $16.4 \div 2$ or 8.2 feet

G9C - Directional antennas

G9C01

Which of the following would increase the bandwidth of a Yagi antenna?

Larger diameter elements



G9C02

What is the approximate length of the driven element of a Yagi antenna?

$\frac{1}{2}$ wavelength

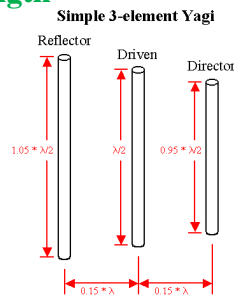

G9C03

Which statement about a three-element, single-band Yagi antenna is true?

The director is normally the shortest element

G9C04

Which statement about a three-element, single-band Yagi antenna is true?

The reflector is normally the longest element

G9C05

How does increasing boom length and adding directors affect a Yagi antenna?

Gain increases

And its beam width decreases

G9C06

What configuration of the loops of a two-element quad antenna must be used for the antenna to operate as a beam antenna, assuming one of the elements is used as a reflector?

The reflector element must be approximately 5 percent longer than the driven element

G9C07

What does "front-to-back ratio" mean in reference to a Yagi antenna?

The power radiated in the major radiation lobe compared to the power radiated in exactly the opposite direction

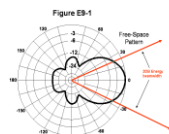

G9C08

What is meant by the "main lobe" of a directive antenna?

The direction of maximum radiated field strength from the antenna

G9C09

How does the gain of **two** 3-element horizontally polarized Yagi antennas spaced vertically 1/2 wavelength apart typically compare to the gain of a single 3-element Yagi?

Approximately 3 dB higher

G9C10

Which of the following is a Yagi antenna design variable that could be adjusted to optimize forward gain, front-to-back ratio, or SWR bandwidth?

- A. The physical length of the boom**
- B. The number of elements on the boom**
- C. The spacing of each element along the boom**
- D. All of these choices are correct**

G9C11

What is the purpose of a gamma match used with Yagi antennas?

To match the relatively low feed point impedance to 50 ohms

G9C12

Which of the following is an advantage of using a gamma match for impedance matching of a Yagi antenna to 50 ohm coax feed line?

It does not require that the elements be insulated from the boom

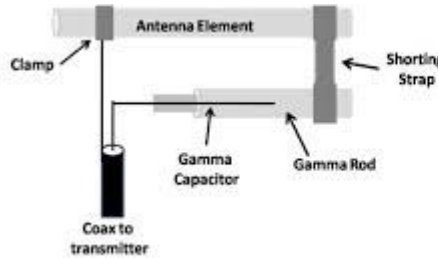
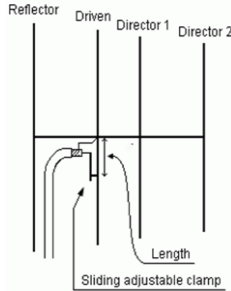

G9C13

Approximately how long is each side of the driven element of a quad antenna?

1/4 wavelength

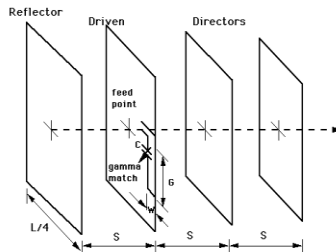

G9C14

How does the forward gain of a two-element quad antenna compare to the forward gain of a three-element Yagi antenna?

About the same

G9C15

Approximately how long is each side of the reflector element of a quad antenna?

Slightly more than 1/4 wavelength

G9C16

How does the gain of a two-element delta-loop beam compare to the gain of a two-element quad antenna?

About the same

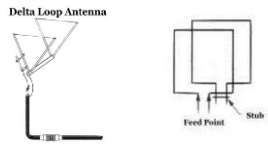

G9C17

Approximately how long is each leg of a symmetrical delta-loop antenna?

1/3 wavelength

G9C18

What happens when the feed point of a quad antenna of any shape is moved from the midpoint of the top or bottom to the midpoint of either side?

The polarization of the radiated signal changes from horizontal to vertical

G9C19

How does antenna gain stated in dBi compare to gain stated in dBd for the same antenna?

dBi gain figures are 2.15 dB higher than dBd gain figures

dBi is dB intrinsic (gain relative to a theoretical spherical antenna). dBd is gain relative to a dipole.

G9C20

What is meant by the terms dBi and dBd when referring to antenna gain?

dBi refers to an isotropic antenna, dBd refers to a dipole antenna

dBi refers to a reference level of an ideal point source of energy that radiates equally in all directions in a sphere surrounding the point RF source.

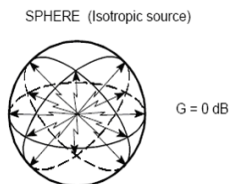

Since it is not practical to build an isotropic source many antenna gains are referenced to a dipole, which has 2.14 dB gain over the theoretical isotropic antenna. Giving gain in dBi makes the antenna look better. When comparing antennas, be sure you know what the gain number is referenced to so the comparison is between equals.

G9D - Specialized antennas

G9D01

What does the term NVIS mean as related to antennas?

Near Vertical Incidence sky-wave

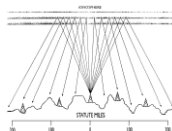

G9D02

Which of the following is an advantage of an NVIS antenna?

High vertical angle radiation for working stations within a radius of a few hundred kilometers

G9D03

At what height above ground is an NVIS antenna typically installed?

Between 1/10 and 1/4 wavelength

G9D04

What is the primary purpose of antenna traps?

To permit multiband operation

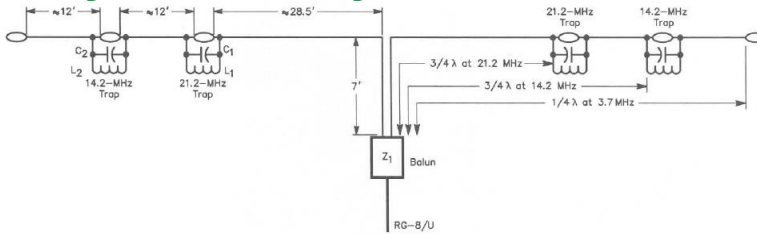

G9D05

What is an advantage of vertical stacking of horizontally polarized Yagi antennas?

It narrows the main lobe in elevation

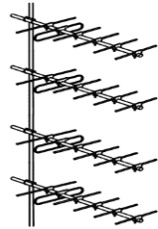

G9D06

Which of the following is an advantage of a log periodic antenna?

Wide bandwidth

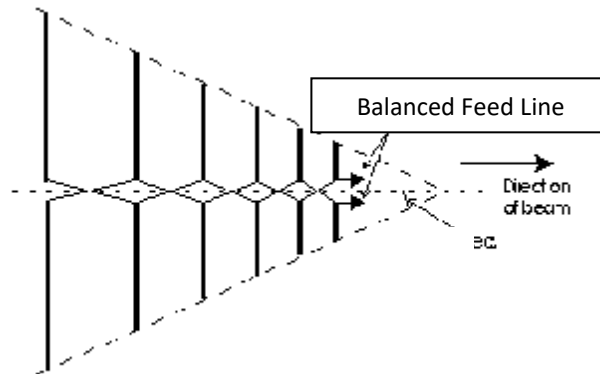

G9D07

Which of the following describes a log periodic antenna?

Length and spacing of the elements increase logarithmically from one end of the boom to the other

G9D08

Why is a Beverage antenna not used for transmitting?

It has high losses compared to other types of antennas

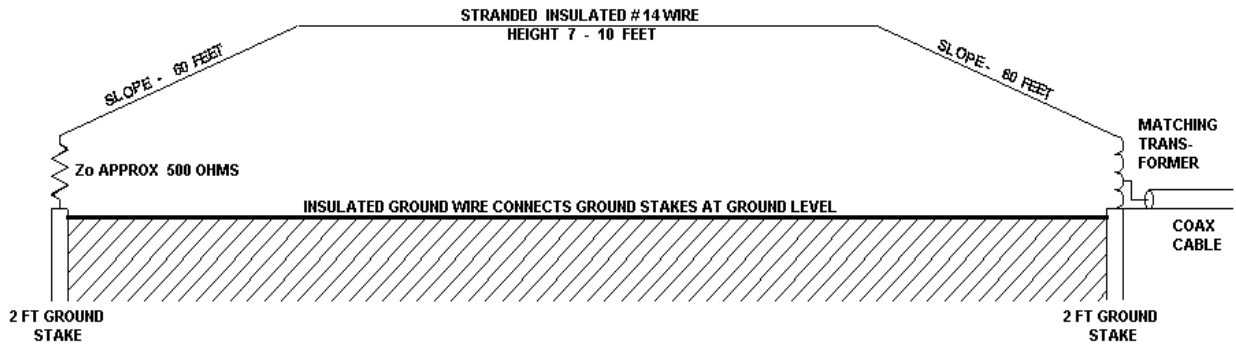

The Beverage antenna is a long wire receiving antenna mainly used in the high frequency (shortwave) and medium frequency radio bands. It is used by amateur radio, shortwave listening, and long-wave radio DX and military applications.

A Beverage antenna consists of a horizontal wire one or two wavelengths long (hundreds of feet at HF to several kilometers for long-wave) suspended above the ground, with the feedline to the receiver attached to one end and the other terminated through a resistor to ground. The feedline is often a 50 or 75 ohm coaxial transmission line connected to the receiver through an impedance-matching transformer, while a 450 ohm non-inductive resistor attached to a ground stake is often used at the other end. The antenna has a unidirectional radiation pattern with the main lobe off the resistor-terminated end.

G9D09

Which of the following is an application for a Beverage antenna?

Directional receiving for low HF bands

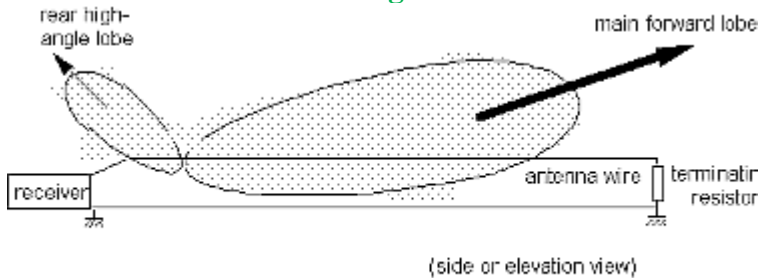

G9D10

Which of the following describes a Beverage antenna?

A very long and low directional receiving antenna

G9D11

Which of the following is a disadvantage of multiband antennas?

They have poor harmonic rejection

SUBELEMENT G0 – ELECTRICAL AND RF SAFETY

[2 Exam Questions – 2 Groups]

G0A - RF safety principles, rules and guidelines; routine station evaluation

G0A01

What is one way that RF energy can affect human body tissue?

It heats body tissue

G0A02

Which of the following properties is important in estimating whether an RF signal exceeds the maximum permissible exposure (MPE)?

- A. Its duty cycle
- B. Its frequency
- C. Its power density
- D. All of these choices are correct

Read the RF Exposure and you ARRL Publication or use MPE evaluation check list in appendix (page 89)

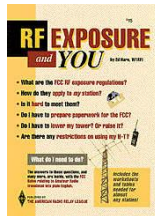

G0A03 [97.13(c)(1)]

How can you determine that your station complies with FCC RF exposure regulations?

- A. By calculation based on FCC OET Bulletin 65
- B. By calculation based on computer modeling
- C. By measurement of field strength using calibrated equipment
- D. All of these choices are correct

G0A04

What does "time averaging" mean in reference to RF radiation exposure?

The total RF exposure averaged over a certain time

G0A05

What must you do if an evaluation of your station shows RF energy radiated from your station exceeds permissible limits?

Take action to prevent human exposure to the excessive RF fields

G0A06

What precaution should be taken when installing a ground-mounted antenna?

It should be installed such that it is protected against unauthorized access

G0A07

What effect does transmitter duty cycle have when evaluating RF exposure?

A lower transmitter duty cycle permits greater short-term exposure levels

G0A08

Which of the following steps must an amateur operator take to ensure compliance with RF safety regulations when transmitter power exceeds levels specified in FCC Part 97.13?

Perform a routine RF exposure evaluation

G0A09

What type of instrument can be used to accurately measure an RF field?

A calibrated field strength meter with a calibrated antenna

G0A10

What is one thing that can be done if evaluation shows that a neighbor might receive more than the allowable limit of RF exposure from the main lobe of a directional antenna?

Take precautions to ensure that the antenna cannot be pointed in their direction

G0A11

What precaution should you take if you install an indoor transmitting antenna?

Make sure that MPE limits are not exceeded in occupied areas

G0A12

What precaution should you take whenever you make adjustments or repairs to an antenna?

Turn off the transmitter and disconnect the feed line

G0B - Safety in the ham shack: electrical shock and treatment, safety grounding, fusing, interlocks, wiring, antenna and tower safety

G0B01

Which wire or wires in a four-conductor connection should be attached to fuses or circuit breakers in a device operated from a 240 VAC single phase source?

Only the two wires carrying voltage

G0B02

What is the minimum wire size that may be safely used for a circuit that draws up to 20 amperes of continuous current?

AWG number 12

**Wire-size-amp chart
for home**

Copper wire size	Ampacity of wire
18	Lamp cord
16	Toaster cord
14	15 Amps
12	20
10	30
8	50
6	65 Amps
4	85
3	100
2	115
1	130
1/0	150
2/0	175
3/0	200
4/0	230

G0B03

Which size of fuse or circuit breaker would be appropriate to use with a circuit that uses AWG number 14 wiring?

15 amperes

Note: For amateur radio 12 volt DC applications larger wire sizes would be used due to voltage drop in the wires. A few volts drop at 120 volts is not a problem but a few volts drop in a 12 volt powered system would potentially lower the voltage so it would not be enough to properly operate your radio(s).

G0B04

Which of the following is a primary reason for not placing a gasoline-fueled generator inside an occupied area?

Danger of carbon monoxide poisoning

G0B05

Which of the following conditions will cause a Ground Fault Circuit Interrupter (GFCI) to disconnect the 120 or 240 Volt AC line power to a device?

Current flowing from one or more of the voltage-carrying wires directly to ground

G0B06

Why must the metal enclosure of every item of station equipment be grounded?

It ensures that hazardous voltages cannot appear on the chassis

G0B07

Which of these choices should be observed when climbing a tower using a safety belt or harness?

Confirm that the belt is rated for the weight of the climber and that it is within its allowable service life

G0B08

What should be done by any person preparing to climb a tower that supports electrically powered devices?

Make sure all circuits that supply power to the tower are locked out and tagged

G0B09

Why should soldered joints not be used with the wires that connect the base of a tower to a system of ground rods?

A soldered joint will likely be destroyed by the heat of a lightning strike

G0B10

Which of the following is a danger from lead-tin solder?

Lead can contaminate food if hands are not washed carefully after handling the solder

G0B11

Which of the following is good practice for lightning protection grounds?

They must be bonded together with all other grounds

G0B12

What is the purpose of a power supply interlock?

To ensure that dangerous voltages are removed if the cabinet is opened

G0B13

What must you do when powering your house from an emergency generator?

Disconnect the incoming utility power feed

G0B14

Which of the following is covered by the National Electrical Code?

Electrical safety inside the ham shack

G0B15

Which of the following is true of an emergency generator installation?

The generator should be located in a well-ventilated area

Appendix of Reference materials



Maximum Permissible Exposure (MPE) evaluation Decision Tree
 See ARRL RF Exposure and You publication or the FCC web site for more information

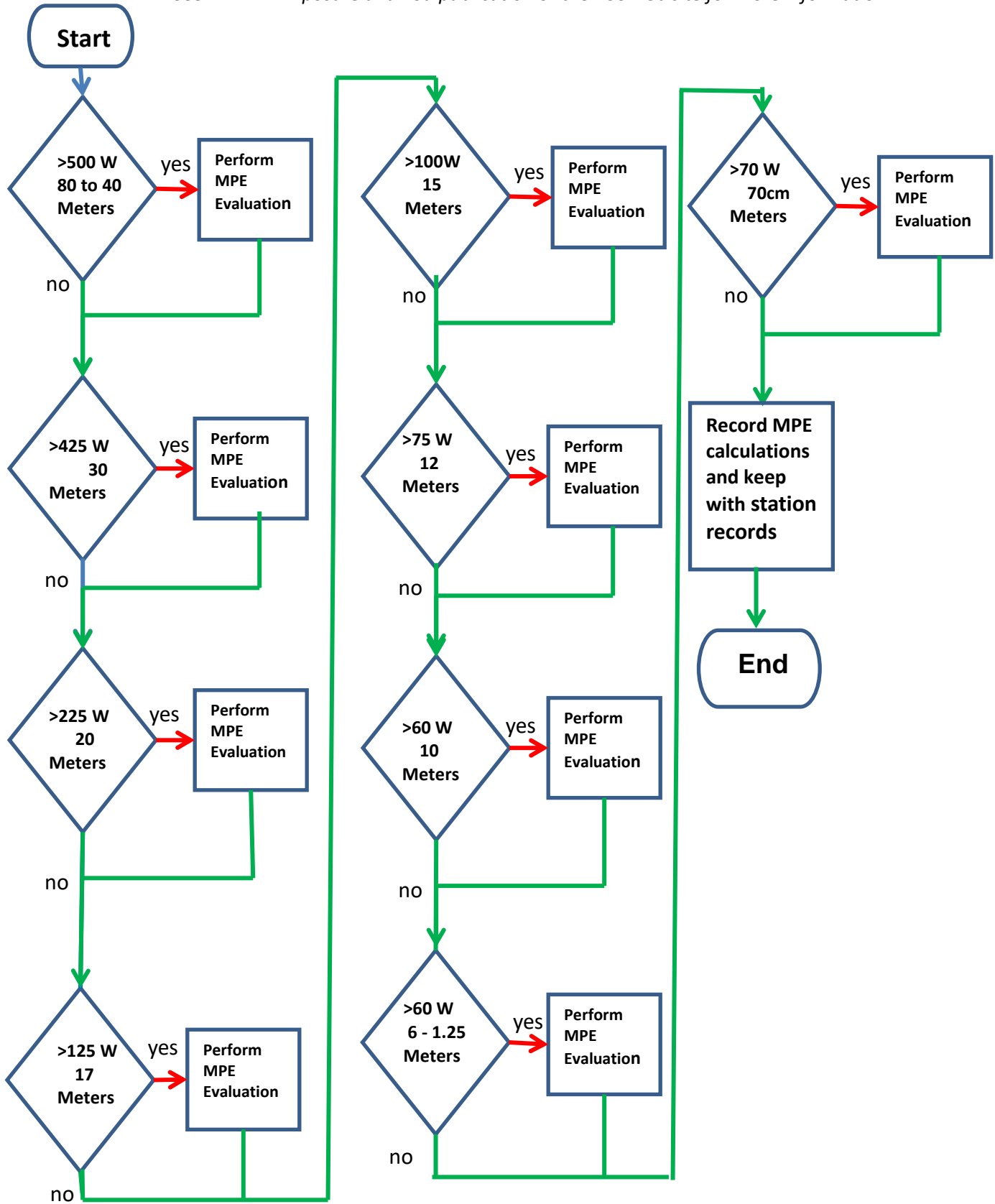

Ohms Law

$I = E \div R$ $R = E \div I$ $E = I * R$ (I-Current (amperes), E= volts, R=Resistance (ohms), P=Power (watts))
 $P = E * I$ $P = E^2 \div R$ $I = P \div E$ $E = V(P * R)$ (I-Current (amperes), E= volts, R=Resistance (ohms), P=Power (watts))

Series connected Resistors

$R = R1 + R2 + R3 +Rx$

Parallel connected Resistors

$$R = \frac{1}{\frac{1}{R_1} + \frac{1}{R_2} + \frac{1}{R_3} + \dots + \frac{1}{R_x}}$$

Series inductors

$L = L1 + L2 + L3 + Lx$

Parallel inductors !!!!!!!!!!!!!!!!!!!!!!!!!!!!!!!

$$L = \frac{1}{\frac{1}{L_1} + \frac{1}{L_2} + \frac{1}{L_3} + \dots + \frac{1}{L_x}}$$

Capacitors in parallel

$C = C1 + C2 + C3 + Cx$

Capacitors in series

$$C = \frac{1}{\frac{1}{C_1} + \frac{1}{C_2} + \frac{1}{C_3} + \dots + \frac{1}{C_x}}$$

RC Time Constant

Capacitance in farads, Resistance in Ohms (will also work with capacitance in microfarads and resistance in Meg ohms)

Time Constant in Seconds = $C * R$ (time constant is also referred to by the Greek letter tau (τ))

Charge vs number of time constants

Time Constant	% Charge /Discharge
1	63.2
2	86.5
3	95
4	98.2
5	99.3

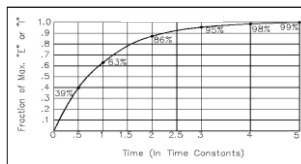
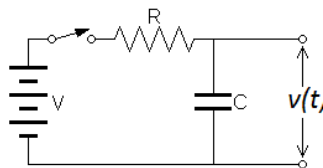
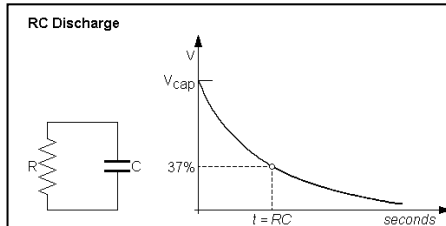

International System of Units (SI)—Metric Units Table

Prefix	Symbol	Multiplication Factor	
exe	E	10+18	1,000,000 000,000,000,000
peta	P	10+15	1,000 000,000,000,000
tera	T	10+12	1,000,000,000,000
giga	G	10+9	1,000,000,000
mega	M	10+6	1,000,000
kilo	k	10+3	1,000
hecto	h	10+2	100
deca	da	10+1	10
(unit)		10+0	1
deci	d	10-1	0.1
centi	c	10-2	0.01
milli	m	10-3	0.001
micro	μ	10-6	0.000001
nano	n	10-9	0.000000001
pico	p	10-12	0.000000000001
femto	f	10-15	0.000,000,000,000,001
atto	a	10-18	0.000,000,000,00,000,0001

The Decibel (dB)

Many times in electronics is necessary to compare values that are quite far apart to make this comparison we use a term called the decibel or dB. If we had a transmitter with 1,000 watt of output power and a receiver with a 0.01 μ watt sensitivity the ratio between these two values would be 100 Billion ($100 * 10^{12}$) to 1, which is a difficult number to work with. By expressing the value as an exponent of 10 we can make these large ratios more manageable (in the above case of 100 billion to one it would be 110 dB). Using dB values we can calculate the effect of gains and losses in networks. The dB value for power in a network can be calculated using the following equation :

$$\text{dB} = 10 (\log (\text{power 1} \div \text{power 2})) \quad (\text{use the base 10 logarithm key not natural log key})$$

Examples:

What is the power ratio in dB between power levels of 50 watts and 100 watts?

$$\text{dB} = 10 (\log (P1/ P2)) \text{ or } \text{dB} = 10(\log(50/100)) \text{ or } \text{dB} = 10 (\text{Log}(0.5)) \text{ or } \text{dB} = 10(-0.301) \text{ or } \text{dB} = -3.01$$

What is the ratio in dB between the power levels of 100 watts with 50 watts?

$$\text{dB} = 10 (\log (P1 \div P2)) \text{ or } \text{dB} = 10(\log(100 \div 50)) \text{ or } \text{dB} = 10 (\text{Log}(2)) \text{ or } \text{dB} = 10(0.301) \text{ or } \text{dB} = 3.01$$

What is the power ratio in dB between a power level of 85 watts with 13 watts?

$$\text{dB} = 10 (\log (P1 \div P2)) \text{ or } \text{dB} = 10(\log(85 \div 13)) \text{ or } \text{dB} = 10 (\text{Log}(6.538)) \text{ or } \text{dB} = 10(0.815) \text{ or } \text{dB} = 8.15$$

To find a power ratio from a dB value take the dB value, divide it by 10 then raise ten to that power.

$$\text{Power Ratio} = 10 ^{(\text{dB} \div 10)}$$

Examples:

What is the power ratio expressed by 15 dB?

$$\text{Power Ratio} = 10 ^{(\text{dB}/10)} \text{ or } \text{Ratio} = 10 ^{(15/10)} \text{ or } \text{Ratio} = 10 ^{(1.5)} \text{ or } \text{Ratio} = 31.62$$

What is the ratio expressed by 2 dB?

$$\text{Ratio} = 10 ^{(\text{dB}/10)} \text{ or } \text{Ratio} = 10 ^{(2/10)} \text{ or } \text{Ratio} = 10 ^{(0.200)} \text{ Ratio} = 1.585$$

What is the ratio expressed by -12 dB

$$\text{Power Ratio} = 10 ^{(\text{dB}/10)} \text{ or } \text{Ratio} = 10 ^{(15/10)} \text{ or } \text{Ratio} = 10 ^{(-1.2)} \text{ Ratio} = .0631$$

To answer questions on the general exam you can remember the above equations and calculations or remember these few simple dB ratios that will get you through all the exam questions.

Gain (+)	dB	Loss (-)
x ~1.2	1	~80%
x 1.6	2	63%
x 2	3	50%
x 10	10	10%

Reactance is the equivalent AC resistance of a capacitor or inductor at a given frequency

Equivalent AC resistance (reactance) of an inductor can be calculated by the equation:

$$X_L = 2\pi fL$$

(Frequency (f) in hertz, inductance (L) in henries **or** frequency in kilohertz, inductance in millihenrys **or** frequency in megahertz and inductance in microhenries)

Example 20 mH inductor at 3.5 kHz

$$X_L = 2\pi FL = 6.28 \times .02 \times 3,500 = 6.28 \times 70 = 439.8 \Omega \text{ or}$$

$$X_L = 2\pi FL = 6.28 \times 20 \times 3.5 = 6.28 \times 70 = 439.8 \Omega \text{ or}$$

$$X_L = 2\pi FL = 6.28 \times 20,000 \times .0035 = 6.28 \times 70 = 439.8 \Omega$$

Equivalent AC resistance (reactance) of a capacitor can be calculated by the equation:

$$X_c = 1 \div (2\pi FC) \text{ frequency is in Hertz and Capacitance is in Farads. } \text{or}$$

**Microfarads and
Megahertz**

Example 20 μ F capacitor at 3.5 KHz

$$X_c = 1/(2\pi FC) = 1/(6.28 \times .000,020 \times 3,500) = 1/(6.28 \times .07) = 2.27 \Omega \text{ or}$$

$$X_c = 1/(2\pi FC) = 1/(6.28 \times 20 \times .0035) = 1/(6.28 \times .7) = 1/.44 = 2.27 \Omega$$

Effective Radiated Power

Let's use an example with the following characteristics:

- Power output from radio = 50 watts
- Feed line loss = - 4dB
- Duplexer loss = -2 dB
- Circulator loss = - 1dB
- Antenna Gain = + 4 dB

First we calculate the overall ERP as follows:

$$ERP = 50 \text{ watts} + (-4 + -2 + -1 + 4) \text{ or } 50 \text{ watts} - 3 \text{ dB or } 25 \text{ watts}$$

Operational Amplifiers

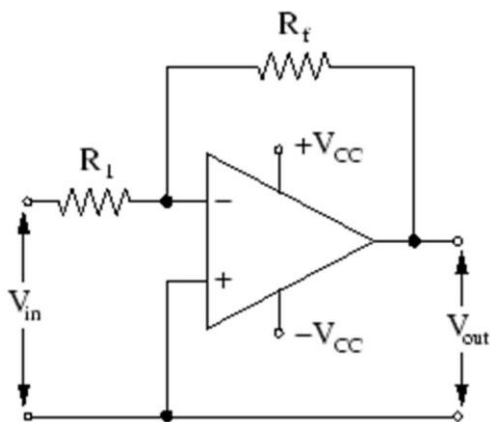

$$Gain = R_f \div R_i$$

If the feedback resistor was 100,000 Ω and the input resistor was 1,000 Ω the gain would be 100,000/1,000 or 100. Since the input impedance of the amplifier is very high there is no current flowing through R_i , and the voltage applied is accurately amplified. In this configuration the output signal polarity is inverted relative to the input.

AC Voltage Calculations

The RMS (Root Mean Square) value for a sine wave is the value of an equivalent DC voltage required to generate the same amount of power or heat in a resistive load.

For a pure sine wave the equivalent RMS voltage is .707 times the peak voltage. Conversely the peak voltage can be calculated as 1.414 times the RMS Voltage.

*The peak voltage for standard 120V RMS AC line voltage is
Peak Voltage = 1.414 x 120V or ~170 volts peak.*

*The peak to peak would be two times the peak voltage
Voltage Peak to peak = 2 x 170 or 340 Volts pp*

An AC voltage that reads 65 volts on an RMS meter will have a peak to peak voltage 65 x 1.414 x 2 or ~184 Volts.

The average power dissipated by a 50 ohm resistor during one cycle of voltage with a peak voltage of 35 volts is 12.2 Watts.

$$P(\text{avg})^2 = (V_{\text{rms}})^2 \div R \text{ or } (0.707 \times 35)^2 \div 50 \text{ or } 12.24 \text{ watts}$$

Transmitter Power Measurements

The PEP (Peak Envelope Power) output for a transmitter with an observed 30 volt peak envelope voltage (as seen on an oscilloscope across a 50 Ω load) would be 9 watts. To determine the PEP power we take the peak voltage and multiply it by 0.707 to get the Peak of the RMS voltage then using the Peak of the RMS voltage we calculate power using the equation:

$$P(\text{watts}) = V(\text{RMS})^2 \div R (\text{load})$$

$$PEP (\text{watts}) = (V(\text{peak}) \times .707)^2 \div 50 \text{ or } (21.2)^2 \div 50 \text{ or } 449 \div 50 = 8.99 \text{ Watts}$$

Amplifier efficiency

Amplifier efficiency is the ratio of output signal power divided by power supply input times 100%.

$$\text{Efficiency \%} = P(\text{out}) \div P(\text{input}) \times 100$$

A typical 1500 Watt PEP class B amplifier will require 2500 watts of DC input power (assume 60% efficiency). A class A amplifier will be typically 25 to 35% efficient.

$$P(\text{power supply input}) \div P(\text{signal power output}) \text{ or Efficiently} = 1500 \text{ Watts} \div 0.60 \text{ or } 2500 \text{ Watts}$$

Transmission lines

The Velocity Factor of cable is calculated as the Velocity of a wave in the cable divided by the velocity in a perfect cable (which would be the speed of light).

$$VF = V (\text{transmission line}) \div V (\text{speed of light})$$

Since a wave moves slower in a coaxial cable its physical length will be shorter than the electrical length. The electrical length is the wavelength in a free space. The physical length is the actual wavelength in the cable which is shorter than the electrical wavelength because the wave is slowed down by the cable. A typical velocity factor for common coaxial cable with a polyethylene dielectric, like RG8, is about 0.66

The physical length of a one quarter wavelength transmission line with a velocity factor of 0.66 at 14.1 MHz would be 3.5 Meters.

$$\text{Physical length} = [\text{Wavelength} \div 4] \times \text{Velocity Factor}$$

$$PL = ((300 \div 14.1) \div 4) \times 0.66 \text{ or } (5.32) \times .66 \text{ or } 3.5 \text{ meters}$$

Transformers

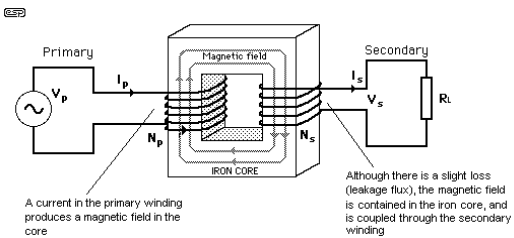
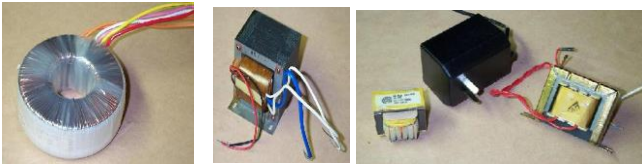

The magnitude of the voltage in the secondary is determined by a very simple formula, which determines the "turn's ratio" (N) of the component - this is traditionally calculated by dividing the secondary turns by the primary turns.

$$N = Ts \div Tp$$

Tp is simply the number of turns of wire that make up the primary winding, and Ts is the number of turns of the secondary. A transformer with 500 turns on the primary and 50 turns on the secondary has a turns ratio of 1:10 (i.e. 1 ÷ 10 or 0.1)

$$Vs = Vp * N$$

We can simply rearrange the formula so that the turn's ratio can be deduced from the primary and secondary voltages.

$$N = Vs \div Vp$$

If a voltage of 240V ACrms is applied to the primary, we would expect 24Vrms on the secondary, and this is indeed what will be measured. The transformer has an additional useful function - not only is the voltage "transformed", but so is the current.

Based on the input vs output voltage the turns ratio would equal $240 \div 24$ or 10

If a current of 1A were drawn by the primary in the above example, then a current of 10A would be available at the secondary (the current from the secondary is proportional to the turns ratio) This would be true if the transformer were 100% efficient, but due to losses the secondary available current may be slightly less than expected.

How a Transformer Works

At no load, an ideal transformer draws virtually no current from the mains, since it is simply a large inductance. The whole principle of operation is based on induced magnetic flux, which not only creates a voltage (and current) in the secondary, but the primary as well! It is this characteristic that allows any inductor to function as expected, and the voltage generated in the primary is called a "back EMF" (electromotive force). The magnitude of this voltage is such that it almost equals (and is effectively in the same phase as) the applied EMF.

- When you apply a load to the output (secondary) winding, a current is drawn by the load, and this is reflected through the transformer to the primary. As a result, the primary must now draw more current from the mains. The source of energy is usually connected to the primary winding of a transformer.*
- When there is no current being drawn from the secondary of a transformer the current in the primary is called the magnetizing current.*

Example

*What is the voltage across the 500 turn secondary of a transformer with a 2250 turn primary connected to 120 VAC?
Secondary Voltage = Primary voltage x turns ratio or $V = 120 \times (500 \div 2250)$ or $V = 120 \times 0.222$ or $V = 26.67$*

Transformers for impedance changing:

The impedance ratio of a transformer is equal to the square of the turns ratio.

$$Z \text{ ratio} = (T \text{ ratio})^2$$

Example:

What is the turn's ratio of a transformer used to match an audio amplifier having a 600 ohm output impedance with a speaker having a 4 ohm impedance?

$$TR = \sqrt{(600 \div 4)} \text{ or } TR = \sqrt{(150)} \text{ or } TR = 12.25:1$$

The Ohms Law Circle

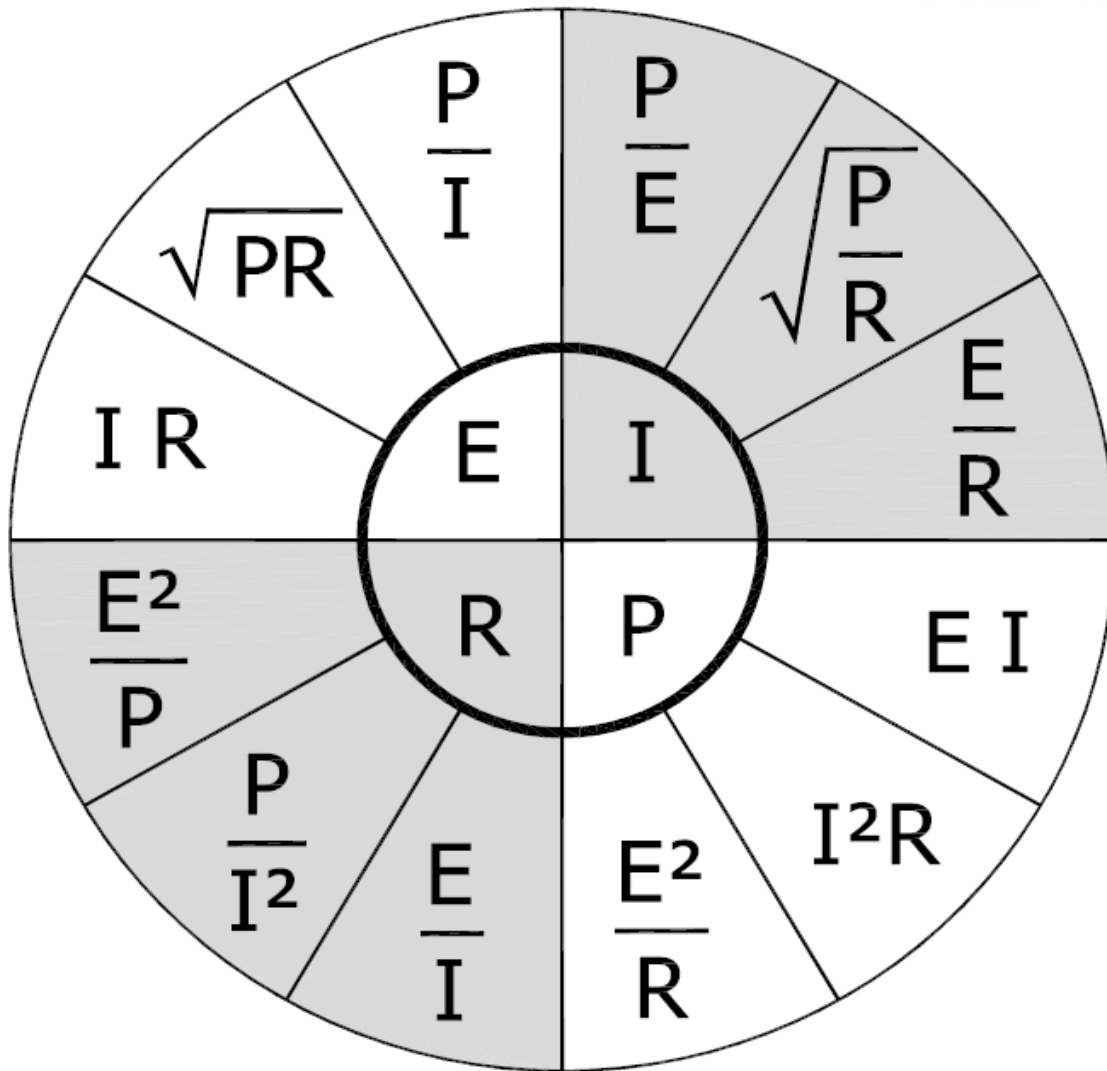

Digital Circuits

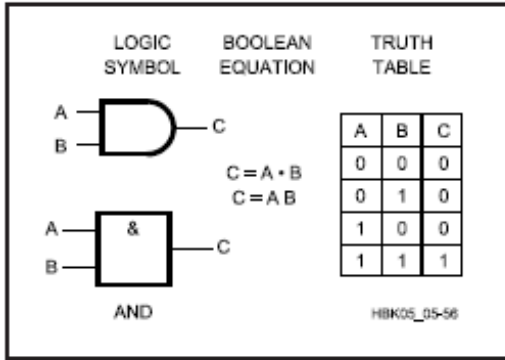

Fig 5.56 — Two-input AND gate.

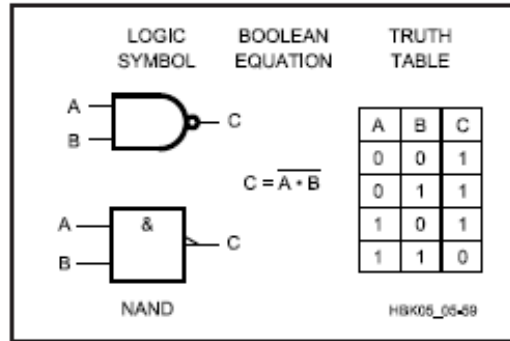

Fig 5.59 — Two-input NAND gate.

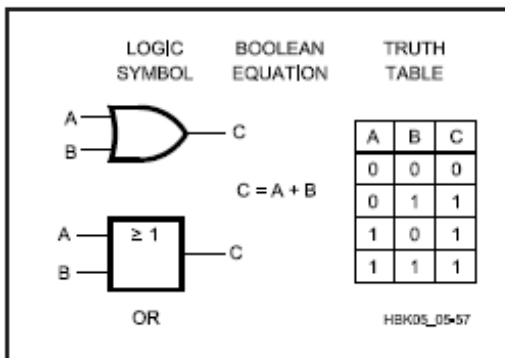

Fig 5.57 — Two-input OR gate.

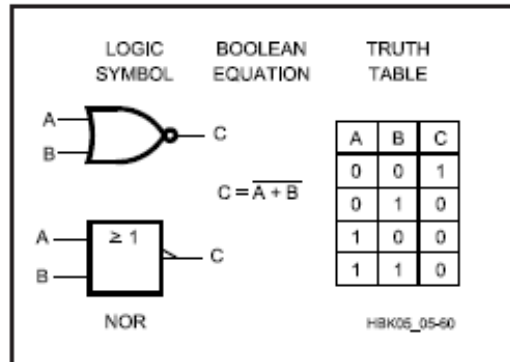

Fig 5.60 — Two-input NOR gate.

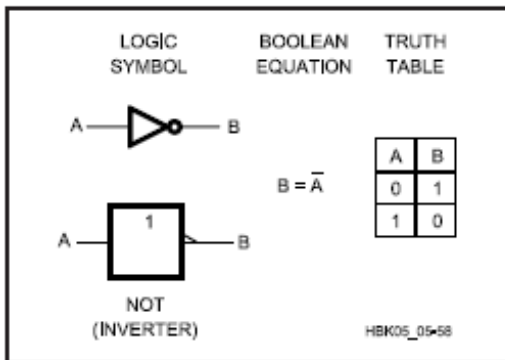

Fig 5.58 — Inverter.

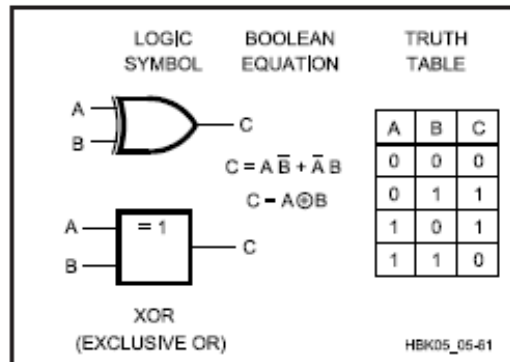

Fig 5.61 — Two-input XOR gate.

VSWR vs return loss – Reflected power and Transmission loss Table

VSWR	Return Loss (dB)	Reflected Power (%)	Transmiss. Loss (dB)	VSWR	Return Loss (dB)	Reflected Power (%)	Transmiss. Loss (dB)
1.00	∞	0.000	0.000	1.38	15.9	2.55	0.112
1.01	46.1	0.005	0.0002	1.39	15.7	2.67	0.118
1.02	40.1	0.010	0.0005	1.40	15.55	2.78	0.122
1.03	36.6	0.022	0.0011	1.41	15.38	2.90	0.126
1.04	34.1	0.040	0.0018	1.42	15.2	3.03	0.132
1.05	32.3	0.060	0.0028	1.43	15.03	3.14	0.137
1.06	30.7	0.082	0.0039	1.44	14.88	3.28	0.142
1.07	29.4	0.116	0.0051	1.45	14.7	3.38	0.147
1.08	28.3	0.144	0.0066	1.46	14.6	3.50	0.152
1.09	27.3	0.184	0.0083	1.47	14.45	3.62	0.157
1.10	26.4	0.228	0.0100	1.48	14.3	3.74	0.164
1.11	25.6	0.276	0.0118	1.49	14.16	3.87	0.172
1.12	24.9	0.324	0.0139	1.50	14.0	4.00	0.18
1.13	24.3	0.375	0.0160	1.55	13.3	4.8	0.21
1.14	23.7	0.426	0.0185	1.60	12.6	5.5	0.24
1.15	23.1	0.488	0.0205	1.65	12.2	6.2	0.27
1.16	22.6	0.550	0.0235	1.70	11.7	6.8	0.31
1.17	22.1	0.615	0.0260	1.75	11.3	7.4	0.34
1.18	21.6	0.682	0.0285	1.80	10.9	8.2	0.37
1.19	21.2	0.750	0.0318	1.85	10.5	8.9	0.40
1.20	20.8	0.816	0.0353	1.90	10.2	9.6	0.44
1.21	20.4	0.90	0.0391	1.95	9.8	10.2	0.47
1.22	20.1	0.98	0.0426	2.00	9.5	11.0	0.50
1.23	19.7	1.08	0.0455	2.10	9.0	12.4	0.57
1.24	19.4	1.15	0.049	2.20	8.6	13.8	0.65
1.25	19.1	1.23	0.053	2.30	8.2	15.3	0.73
1.26	18.8	1.34	0.056	2.40	7.7	16.6	0.80
1.27	18.5	1.43	0.060	2.50	7.3	18.0	0.88
1.28	18.2	1.52	0.064	2.60	7.0	19.5	0.95
1.29	17.9	1.62	0.068	2.70	6.7	20.8	1.03
1.30	17.68	1.71	0.073	2.80	6.5	22.3	1.10
1.31	17.4	1.81	0.078	2.90	6.2	23.7	1.17
1.32	17.2	1.91	0.083	3.00	6.0	24.9	1.25
1.33	17.0	2.02	0.087	3.50	05.1	31.0	1.61
1.34	16.8	2.13	0.092	4.00	04.4	36.0	1.93
1.35	16.53	2.23	0.096	4.50	03.9	40.6	2.27
1.36	16.3	2.33	0.101	5.00	03.5	44.4	2.56
1.37	16.1	2.44	0.106	6.00	02.9	50.8	3.08

Amateur Radio Q Signals

Sign	Meaning
QRA	What is the name of your station? The name of my station is ____.
QRB	How far are you from my station? I am ____ km from you station
QRD	Where are you bound and where are you coming from? I am bound ____ from ____.
QRG	Will you tell me my exact frequency? Your exact frequency is ____ kHz.
QRH	Does my frequency vary? Your frequency varies.
QRI	How is the tone of my transmission? The tone of your transmission is ____ (1-Good, 2-Variable, 3-Bad.)
QRJ	Are you receiving me badly? I cannot receive you, your signal is too weak.
QRK	What is the intelligibility of my signals? The intelligibility of your signals is ____ (1-Bad, 2-Poor, 3-Fair, 4-Good, 5-Excellent.)
QRL	Are you busy? I am busy, please do not interfere
QRM	Is my transmission being interfered with? Your transmission is being interfered with ____ (1-Nil, 2-Slightly, 3-Moderately, 4-Severly, 5-Extremely.)
QRN	Are you troubled by static? I am troubled by static ____ (1-5 as under QRM.)
QRO	Shall I increase power? Increase power.
QRP	Shall I decrease power? Decrease power.
QRQ	Shall I send faster? Send faster (____ WPM.)
QRR	Are you ready for automatic operation? I am ready for automatic operation. Send at ____ WPM.
QRS	Shall I send more slowly? Send more slowly (____ WPM.)
QRT	Shall I stop sending? Stop sending.
QRU	Have you anything for me? I have nothing for you.
QRV	Are you ready? I am ready.
QRW	Shall I inform ____ that you are calling? Please inform ____ that I am calling.
QRX	When will you call me again? I will call you again at ____ hours.
QRY	What is my turn? Your turn is numbered ____.
QRZ	Who is calling me? You are being called by ____.
QSA	What is the strength of my signals? The strength of your signals is ____ (1-Scarcely perceptible, 2-Weak, 3-Fairly Good, 4-Good, 5-Very Good.)
QSB	Are my signals fading? Your signals are fading.
QSD	Is my keying defective? Your keying is defective.
QSG	Shall I send ____ messages at a time? Send ____ messages at a time.
QSJ	What is the charge to be collected per word to ____ including your international telegraph charge? The charge to be collected per word is ____ including my international telegraph charge.
QSK	Can you hear me between you signals and if so can I break in on your transmission? I can hear you between my signals, break in on my transmission.
QSL	Can you acknowledge receipt? I am acknowledging receipt.
QSM	Shall I repeat the last message which I sent you? Repeat the last message.

QSN	Did you hear me on ___ kHz? I did hear you on ___ kHz.
QSO	Can you communicate with ___ direct or by relay? I can communicate with ___ direct (or by relay through ___.)
QSP	Will you relay to ___? I will relay to ___.
QSQ	Have you a doctor on board? (or is ___ on board?) I have a doctor on board (or ___ is on board.)
QSU	Shall I send or reply on this frequency? Send a series of Vs on this frequency.
QSV	Shall I send a series of Vs on this frequency? Send a series of Vs on this frequency.
QSW	Will you send on this frequency? I am going to send on this frequency.
QSY	Shall I change to another frequency? Change to another frequency.
QSZ	Shall I send each word or group more than once? Send each word or group twice (or ___ times.)
QTA	Shall I cancel message number ___? Cancel message number ___.
QTB	Do you agree with my counting of words? I do not agree with your counting of words. I will repeat the first letter or digit of each word or group.
QTC	How many messages have you to send? I have ___ messages for you.
QTE	What is my true bearing from you? Your true bearing from me is ___ degrees.
QTG	Will you send two dashes of 10 seconds each followed by your call sign? I am going to send two dashes of 10 seconds each followed by my call sign.
QTH	What is your location? My location is ___.
QTI	What is your true track? My true track is ___ degrees.
QTJ	What is your speed? My speed is ___ km/h.
QTL	What is your true heading? My true heading is ___ degrees.
QTN	At what time did you depart from ___? I departed from ___ at ___ hours.
QTO	Have you left dock (or port)? I have left dock (or port).
QTP	Are you going to enter dock (or port)? I am going to enter dock (or port.)
QTQ	Can you communicate with my station by means of the International Code of Signals? I am going to communicate with your station by means of the International Code of Signals.
QTR	What is the correct time? The time is ___.
QTS	Will you send your call sign for ___ minutes so that your frequency can be measured? I will send my call sign for ___ minutes so that my frequency may be measured.
QTU	What are the hours during which your station is open? My station is open from ___ hours to ___ hours.
QTV	Shall I stand guard for you on the frequency of ___ kHz? Stand guard for me on the frequency of ___ kHz.
QTX	Will you keep your station open for further communication with me? I will keep my station open for further communication with you.
QUA	Have you news of ___? I have news of ___.
QUB	Can you give me information concerning visibility, height of clouds, direction and velocity of ground wind at ___? Here is the information you requested...
QUC	What is the number of the last message you received from me? The number of the last message I received from you is ___.
QUD	Have you received the urgency signal sent by ___? I have received the urgency signal sent by ___.

QUF	Have you received the distress signal sent by ____? I have received the distress signal sent by ____.
QUG	Will you be forced to land? I am forced to land immediately.
QUH	Will you give me the present barometric pressure? The present barometric pressure is ____ (units).

US Amateurs May Handle Third-Party Traffic With:

V2	Antigua/Barbuda
LO-LW	Argentina
VK	Australia
V3	Belize
CP	Bolivia
E7	Bosnia-Herzegovina
PP-PY	Brazil
VE, VO, VY	Canada
CA-CE	Chile
HJ-HK	Colombia
D6	Comoros (Federal Islamic Republic of)
TI, TE	Costa Rica
CM, CO	Cuba
HI	Dominican Republic
J7	Dominica
HC-HD	Ecuador
YS	El Salvador
C5	Gambia, The
9G	Ghana
J3	Grenada
TG	Guatemala
8R	Guyana
HH	Haiti
HQ-HR	Honduras
4X, 4Z	Israel
6Y	Jamaica
JY	Jordan
EL	Liberia
V7	Marshall Islands
XA-XI	Mexico
V6	Micronesia, Federated States of
YN	Nicaragua
HO-HP	Panama
ZP	Paraguay
OA-OC	Peru
DU-DZ	Philippines
VR6	Pitcairn Island*

V4	St. Kitts/Nevis
J6	St. Lucia
J8	St. Vincent and the Grenadines
9L	Sierra Leone
ZR-ZU	South Africa
3DA	Swaziland
9Y-9Z	Trinidad/Tobago
TA-TC	Turkey
GB	United Kingdom
CV-CX	Uruguay
YV-YY	Venezuela
4U1ITU	ITU - Geneva
4U1VIC	VIC - Vienna

Notes:

Amateur Radio Procedural Signals (PRO Signs)

C Q - Calling any station

AR - "+" over, end of message

K - go, invite any station to transmit

KN - "(" go only, invite a specific station to transmit

BK - invite receiving station to transmit

R - all received OK

AS - please stand by

SK - end of contact (sent before call)

CL - going off the air (clear)

Q Signals (or Q Abbreviations)

Q Signals take the form of a question only when each is followed by a question mark.

QRG - Will you tell me my exact frequency (or that of ___)?

Your exact frequency (or that of ___) is ___ kHz.

QRH - Does my frequency vary?

Your frequency varies.

QRI - How is the tone of my transmission?

The tone of your transmission is ___. (1. Good 2. Variable 3. Bad)

QRJ - Are you receiving me badly?

I can not receive you. Your signals are too weak.

QRK - What is the intelligibility of my signals (or those of ___)?

The intelligibility of your signals (or those of ___) is:

(1. Bad 2. Poor 3. Fair 4. Good 5. Excellent)

QRL - Are you busy?

I am busy (or I am busy with ___). Please do not interfere.

QRM - Is my transmission being interfered with?

Your transmission is being interfered with ___.

(1. Nil 2. Slightly 3. Moderately 4. Severely 5. Extremely)

QRN - Are you troubled by static?

I am troubled by static ---. (1-5 as under QRM)

QRO - Shall I increase power?
Increase power.

QRP - Shall I decrease power?
Decrease power.

QRQ - Shall I send faster?
Send faster _____. (WPM)

QRS - Shall I send more slowly?
Send more slowly _____. (WPM)

QRT - Shall I stop sending?
Stop sending.

QRU - Have you anything for me?
I have nothing for you.

QRV - Are you ready?
I am ready.

QRW - Shall I inform ____ that you are calling on ____ kHz?
Please inform ____ that I am calling on ____ kHz.

QRX - When will you call me again?
I will call you again at ____ hours (on ____ kHz).

QRY - What is my turn?
Your turn is numbered _____.

QRZ - Who is calling me?
You are being called by ____ (on ____ kHz).

QSA - What is the strength of my signals (or those of _____)?
The strength of your signals (or those of _____) is _____.
(1. Scarcely perceptible 2. Weak 3. Fairly good 4. Good 5. Very good)

QSB - Are my signals fading?
Your signals are fading.

QSD - Is my keying defective?
Your keying is defective?

QSG - Shall I send ____ messages at a time?
Send ____ messages at a time.

QSK - Can you hear me in between your signals and if so, can I break in on your transmission?
I can hear you between my signals; break in on my transmission.

QSL - Can you acknowledge receipt?
I am acknowledging receipt.

QSM - Shall I repeat the last message I sent you, or some previous message?
Repeat the last message you sent me [or message(s) number(s) ____].

QSN - Did you hear me (or ____) on ____ kHz?
I did hear you (or ____) on ____ kHz.

QSO - Can you communicate with ____ direct or by relay?
I can communicate with ____ direct (or by relay through ____).

QSP - Will you relay to ____?
I will relay to ____.

QST - General call preceding a message addressed to all amateurs and ARRL members. This is in effect, "CQ ARRL".

QSU - Shall I send or reply on this frequency (or on ____ kHz)?
Send a series of Vs on this frequency (or on ____ kHz).

QSW - Will you send on this frequency (or on ____ kHz)?
I am going to send on this frequency (or on ____ kHz).

QSX - Will you listen to ____ on ____ kHz?
I am listening to ____ on ____ kHz.

QSY - Shall I change to to transmission on another frequency?
Change transmission to another frequency (or ____ kHz).

QSZ - Shall I send each word or group more than once?
Send each word or group twice (or ____ times).

QTA - Shall I cancel message number ____?
Cancel message number ____.

QTB - Do you agree with my counting of words?
I do not agree with your counting of words. I will repeat the first letter or digit of each word or group.

QTC - How many messages have you to send?
I have ____ messages for you (or for ____).

QTH - What is your location?
My location is ____.

QTR - What is the correct time?
The correct time is ____.